

N-Channel Mosfet

Features

- Epoxy meets UL 94 V-0 flammability rating
- High density cell design for low $R_{DS(ON)}$
- Voltage controlled small signal switch
- Rugged and reliable
- ESD Protected
- Lead free in comply with EU RoHS 2011/65/EU directives

Machanical Data

- Case:SOT-23
- Approx. Weight: 8.1mg

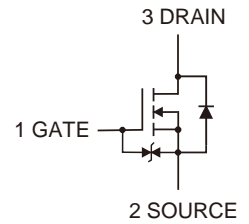
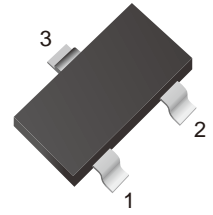

Ordering Information

Part Number	Marking	Shipping	Reel
LT2N7002KCR-TR3	72K	3000PCS Tape&Reel	7 inches
LT2N7002KCR-TR12	72K	12000PCS Tape&Reel	13 inches

Maximum Ratings ($T_a=25^{\circ}\text{C}$)

Symbol	Parameter	Value	Unit
V_{DS}	Drain-source Voltage	60	V
V_{GS}	Gate-source-Voltage	± 20	V
I_D	Drain Current	340	mA
P_d	Total Power Dissipation	300	mW
T_J	Junction Temperature	-55 to 150	$^{\circ}\text{C}$
T_J	Storage Temperature	-55 to 150	$^{\circ}\text{C}$
R	Thermal Resistance from Junction to Ambient	357	$^{\circ}\text{C}/\text{W}$



Electrical Characteristics (T_a=25°C)

Symbol	Parameter	Test Condition	Min	Typ	Max	Unit
V _{(BR)DSS}	Drain-source Voltage Breakdown Voltage	V _{GS} =0V, I _D =10μA	60			V
V _{GS(th)}	Gate-Threshold Voltage (note 1)	V _{DS} =V _{GS} , I _D =1mA	1.0		2.5	V
I _{GSS}	Gate –body Leakage	V _{DS} =0V, V _{GS} =±10V V _{DS} =0V, V _{GS} =±5V V _{DS} =0V, V _{GS} =±20V			±200 ±100 10	nA nA μA
I _{DSS}	Zero Gate Voltage Drain Current	V _{DS} =48V, V _{GS} =0V			1	μA
R _{DS(on)}	Drain-source On-resistance (note 1)	V _{GS} =4.5V, I _D =200mA V _{GS} =10V, I _D =500mA			4 3	Ω
V _{SD}	Diode Forward Voltage (note 1)	V _{GS} =0V, I _S =300mA			1.5	V
Q _r	Recovered charge	V _{GS} =0V, I _S =300mA, V _R =25V dI _S /dt=-100A/μs		30		nC

Dynamic Characteristics

C _{iss}	Input Capacitance	V _{DS} =10V			40	pF
C _{oss}	Output Capacitance	V _{GS} =0V			30	
C _{rss}	Reverse Transfer Capacitance	f=1MHz			10	

Switching Characteristics

t _{d(on)}	Turn on time	V _{DD} =50V, R _L =250Ω			10	ns
t _{d(off)}	Turn off time	R _{GS} =50Ω, V _{GS} =10V, R _G =50Ω			15	
t _{rr}	Reverse recovery time	V _{GS} =0V, I _S =300mA V _R =25V, dI _S /dt=-100A/us		30		

Note: (1) Pulse Test : Pulse width≤300μs, duty cycle≤2%.



Characteristics Curves

Fig.1 Output Characteristics

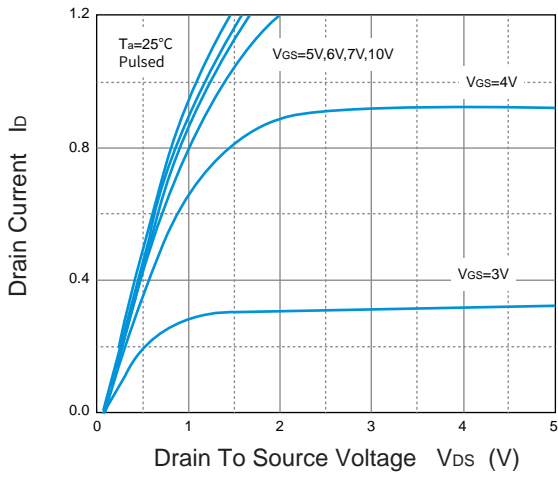

Fig.2 Transfer Characteristics

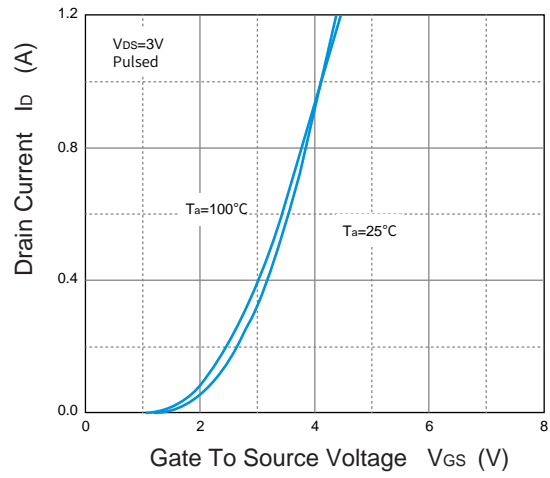

Fig.3 $R_{DS(ON)}$ vs I_D

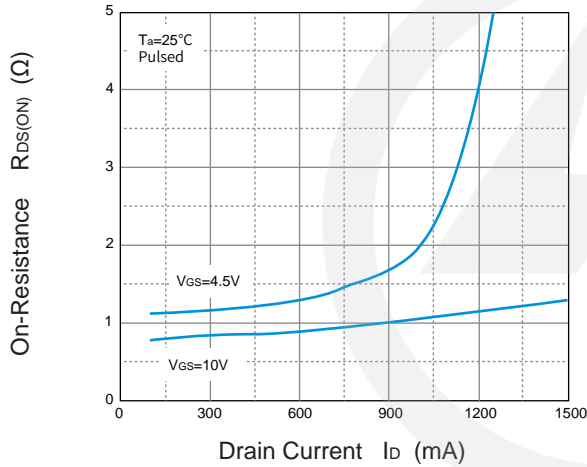

Fig.4 $R_{DS(ON)}$ vs V_{GS}

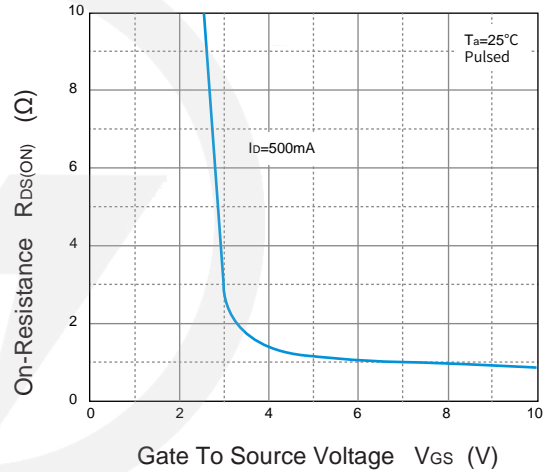

Fig.5 I_S vs V_{SD}

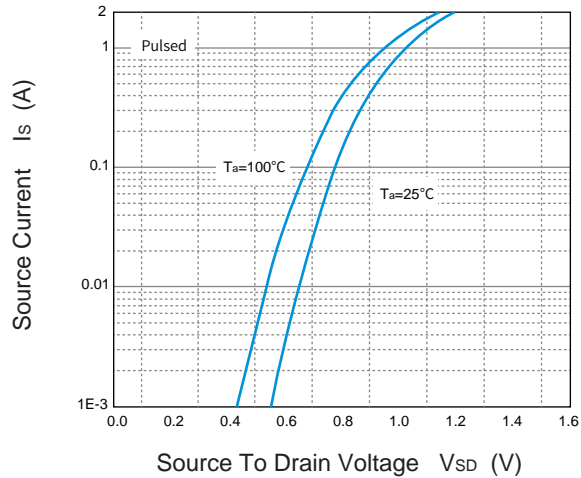
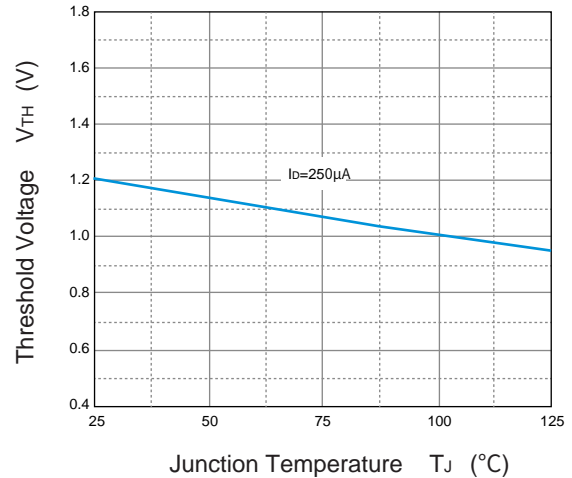
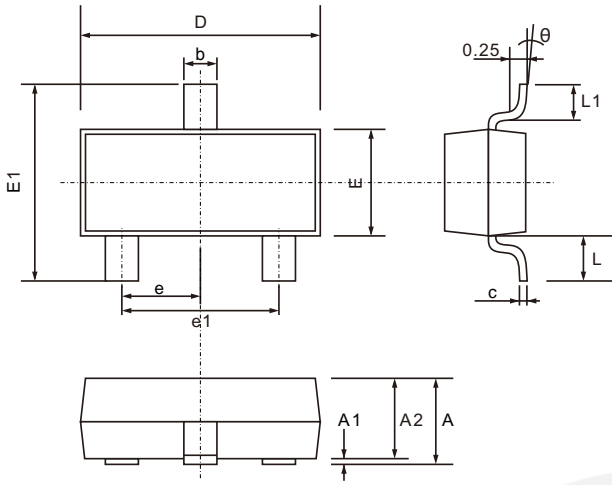

Fig.6 Threshold Voltage



SOT-23 Package Outline

Unit: mm



SYMBOL	DIMENSIONS	
	MIN.	MAX.
A	0.900	1.200
A1	0.000	0.100
A2	0.900	1.050
b	0.300	0.500
c	0.080	0.200
D	2.700	3.100
E	1.200	1.400
E1	2.200	2.600
e	0.950 TYP.	
e1	1.750	2.050
L	0.550 TYP.	
L1	0.300	0.500
θ	0°	8°

SOT-23 Suggested Pad Layout

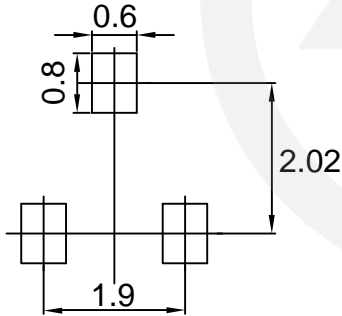

Note:
 1. Controlling dimension: in millimeters.
 2. General tolerance: $\pm 0.05\text{mm}$
 3. The pad layout is for reference purpose only.

Carrier Tape Dimensions

Unit : mm

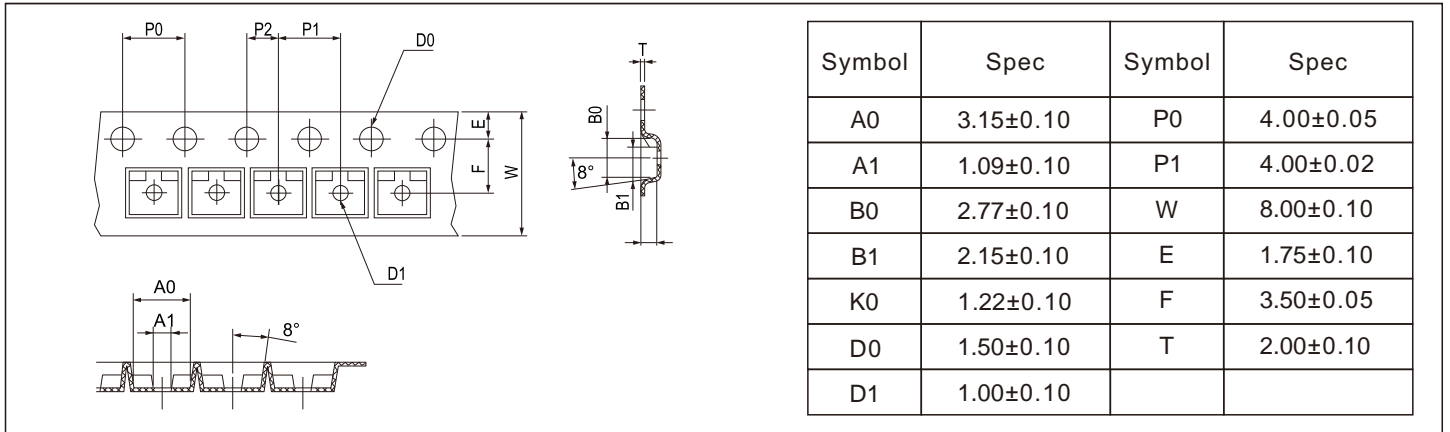

Reel Dimensions

Unit : mm

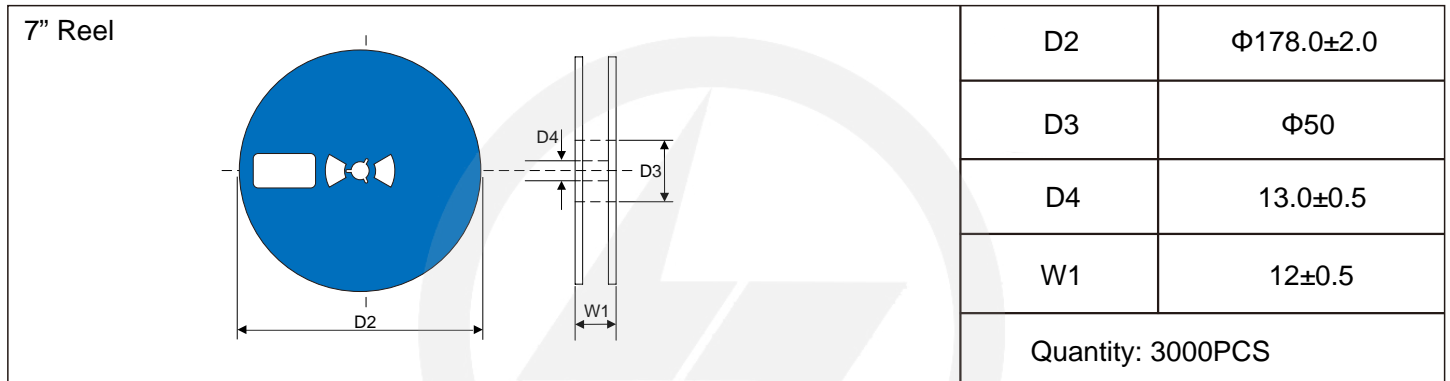

Reel Dimensions

Unit : mm

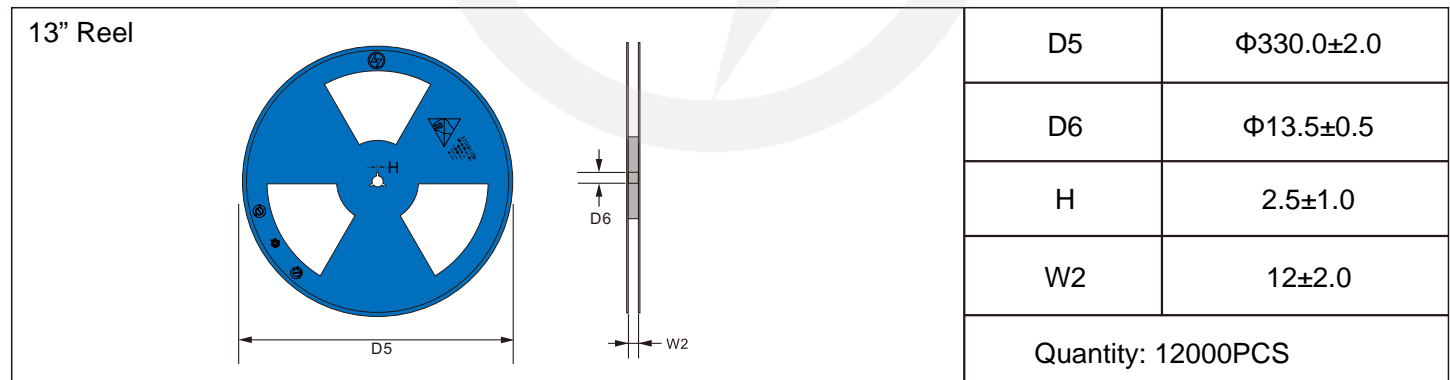

Packaging

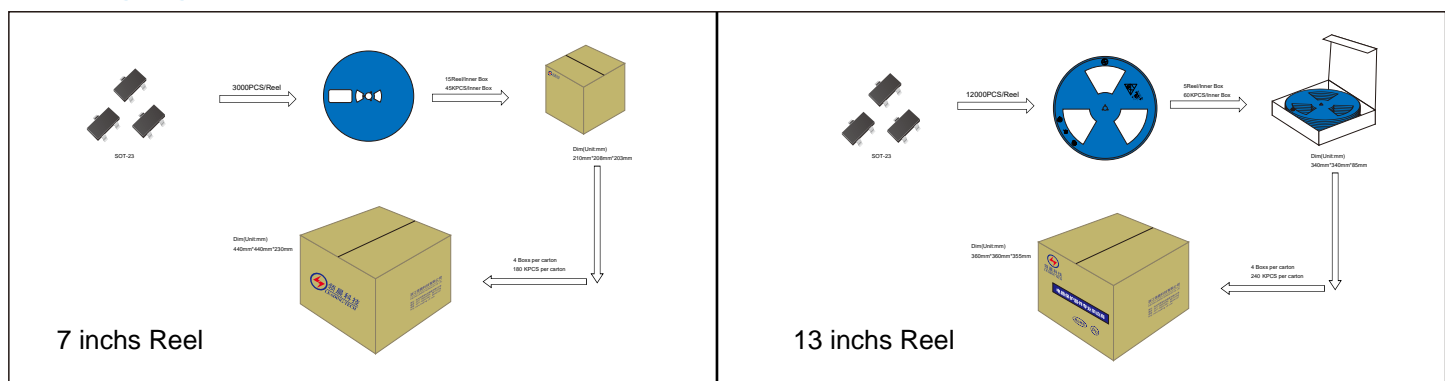



Recommended Soldering Conditions



Recommended Conditions

Profile Feature	Pb-Free Assembly
Average ramp-up rate (T_L to T_P)	3°C/second max.
Preheat	
-Temperature Min ($T_{S\ min}$)	150°C
-Temperature Max ($T_{S\ max}$)	200°C
-Time (min to max) (t_s)	60-180 seconds
$T_{S\ max}$ to T_L	
-Ramp-up Rate	3°C/second max.
Time maintained above:	
-Temperature (T_L)	217°C
-Time (t_L)	60-150 seconds
Peak Temperature (T_P)	260°C
Time within 5°C of actual Peak Temperature (t_p)	20-40 seconds
Ramp-down Rate	6°C/second max.
Time 25°C to Peak Temperature	8 minutes max.

Important Notice and Disclaimer

Leading-Tech reserves the right to make changes to this document and its products and specifications at any time without notice.

Customers should obtain and confirm the latest product information and specifications before final design, purchase or use.

Leading-Tech makes no warranty, representation or guarantee regarding the suitability of its products for any particular purpose, not does Leading-Tech assume any liability for application assistance or customer product design.

Leading-Tech does not warrant or accept any liability with products which are purchase or used for any unintended or unauthorized application.

No license is granted by implication or otherwise under any intellectual property rights of Leading-Tech.

Leading-Tech products are not authorized for use as critical components in life support devices or systems without express written approval of Leading-Tech.

Version Update Information

Series NO.	Enactment/Revision Date	Effective Date	Version	Revision Content	Revision Reason	Revision Person	Note
01	2024.03.20	2024.03.20	3.0	New file	/	Ding	
02	2025.06.12	2025.06.12	3.1	Update packaging information	/	Ding	
03	2026.03.05	2026.03.05	3.2	Package outline E1(max)=2.6mm	/	Ding	