

Transistor (NPN)

Features

- Low saturation voltage
- Lead free in comply with EU RoHS 2011/65/EU directives

Mechanical Data

- Case: SOT-23
- Approx. Weight: 8.1mg

Ordering Information

Part Number	Marking	Shipping	Reel
LT2CR553P -TR1	NG	1000PCS Tape&Reel	7 inches
LT2CR553P -TR3	NG	3000PCS Tape&Reel	13 inches

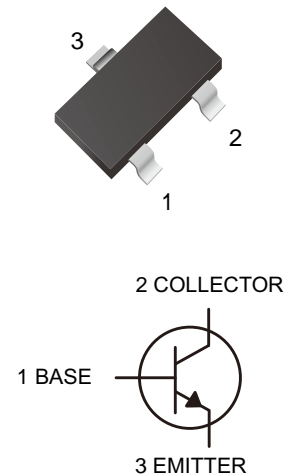

Maximum Ratings ($T_a=25$ unless otherwise noted)

Parameter	Symbol	Value	Unit
Collector Base Voltage	V_{CBO}	50	V
Collector Emitter Voltage	V_{CEO}	50	V
Emitter Base Voltage	V_{EBO}	6	V
Collector Current	I_C	2	A
Maximum Power Dissipation	P_D	500	mW
Junction Temperature	T_J	150	°C
Storage Temperature Range	T_{STG}	-55 to +150	°C

Electrical characteristics ($T_a=25$ unless otherwise specified)

Parameter	Symbol	Min.	Typ.	Max.	Unit
DC Current Gain at $V_{CE} = 2$ V, $I_C = 50$ mA	H_{FE}	180		450	
Collector Base Cutoff Current at $V_{CB} = 50$ V	I_{CBO}			0.1	μ A
Emitter Base Cutoff Current at $V_{EB} = 4$ V	I_{EBO}			0.1	μ A
Collector Base Breakdown Voltage at $I_C = 100$ μ A	$V_{(BR)CBO}$	50			V
Collector Emitter Breakdown Voltage at $I_C = 1$ mA	$V_{(BR)CEO}$	50			V
Emitter Base Breakdown Voltage at $I_E = 100$ μ A	$V_{(BR)EBO}$	6			V
Collector Emitter Saturation Voltage at $I_C = 700$ mA, $I_B = 35$ mA	$V_{CE(sat)}$			0.35	V
Base Emitter Saturation Voltage at $I_C = 500$ mA, $I_B = 50$ mA	$V_{BE(sat)}$			1.2	V
Transition Frequency at $V_{CE} = 10$ V, $I_E = 300$ mA, $f=100$ MHz	F_T		360		MHz

Characteristics Curves

Fig.1 Ground Emitter Propagation Characteristics

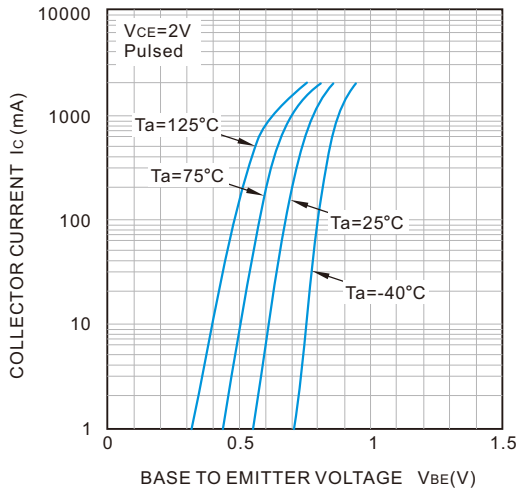

Fig.2 Typical Output Characteristics

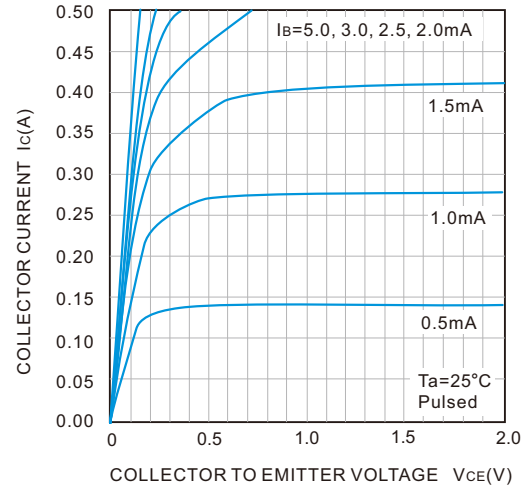

Fig.3 DC Current Gain vs Collector Current (1)

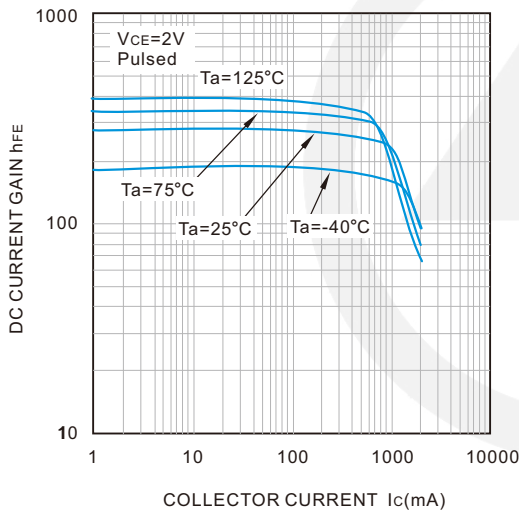

Fig.4 DC Current Gain vs Collector Current (2)

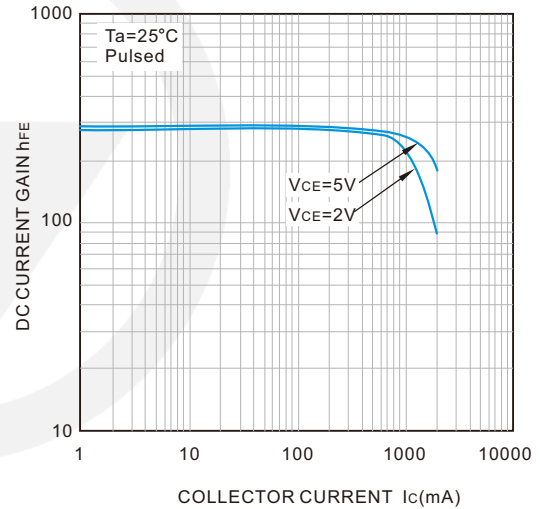

Fig.5 Collector-Emitter Saturation Voltage vs Collector Current (1)

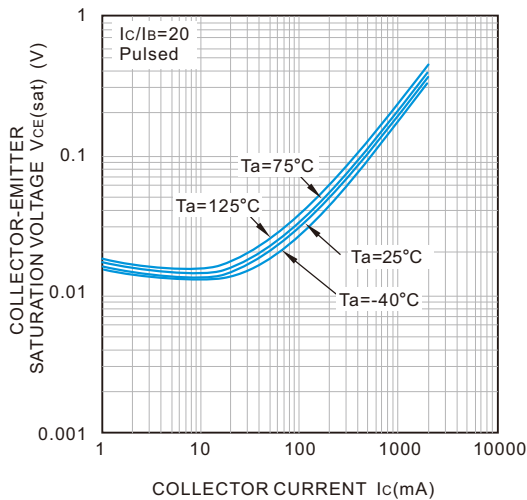

Fig.6 Collector-Emitter Saturation Voltage vs Collector Current (2)

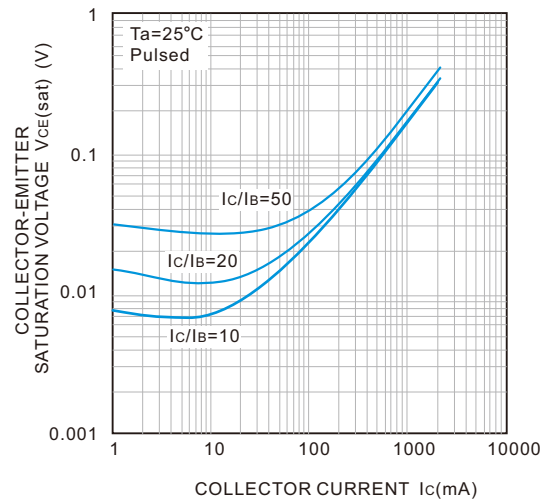



Fig.7 Base-Emitter Saturation Voltage vs Collector Current

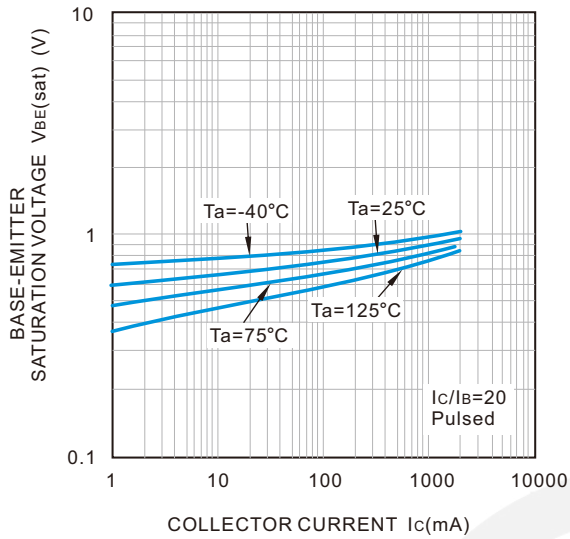

Fig.8 Gain Bandwidth Product vs Emitter Current

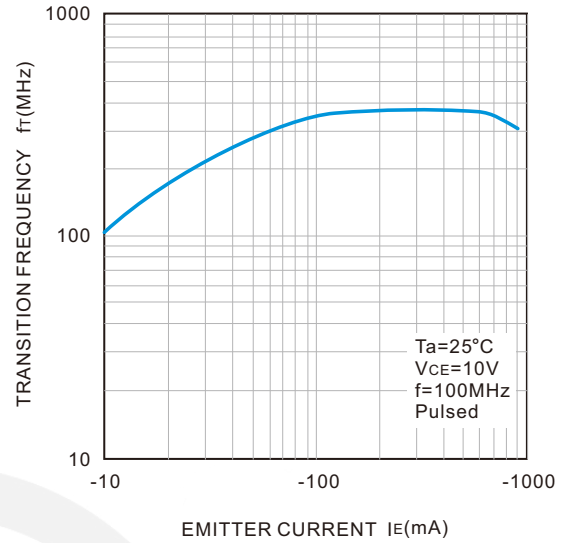

Fig.9 Emitter Input Capacitance vs. Emitter-Base Voltage Collector Output Capacitance vs. Collector-Base Voltage

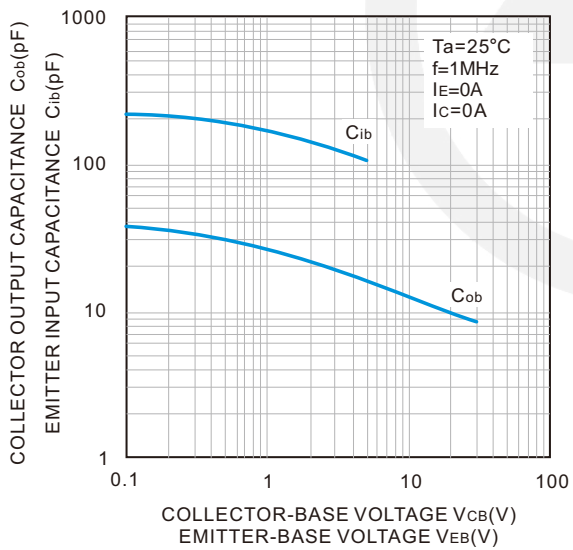
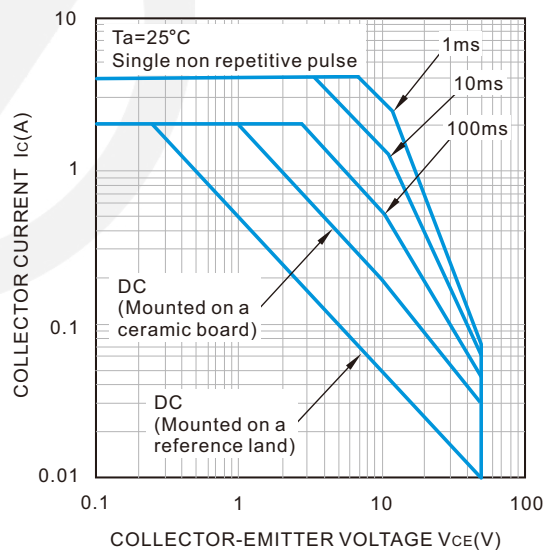
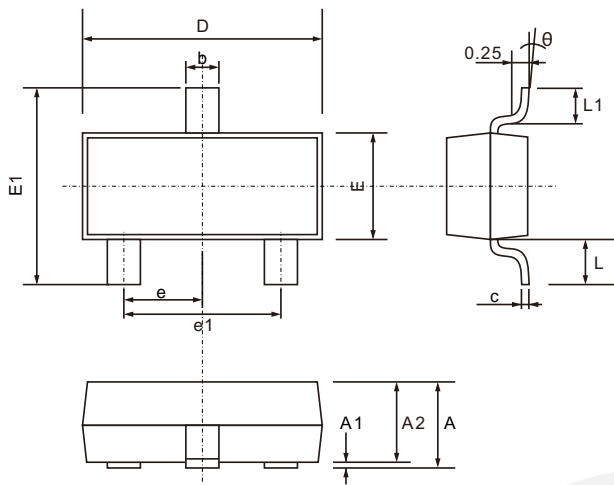

Fig.10 Safe Operating Area



SOT-23 Package Outline

Unit : mm



SYMBOL	DIMENSIONS	
	MIN.	MAX.
A	0.900	1.200
A1	0.000	0.100
A2	0.900	1.050
b	0.300	0.500
c	0.080	0.200
D	2.700	3.100
E	1.200	1.400
E1	2.200	2.600
e	0.950 TYP.	
e1	1.750	2.050
L	0.550 TYP.	
L1	0.300	0.500
θ	0°	8°

SOT-23 Suggested Pad Layout

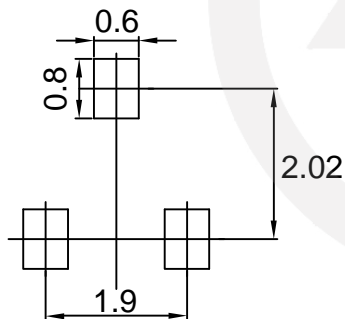

Note:
 1. Controlling dimension: in millimeters.
 2. General tolerance: ± 0.05 mm
 3. The pad layout is for reference purpose only.

Carrier Tape Dimensions

Unit : mm

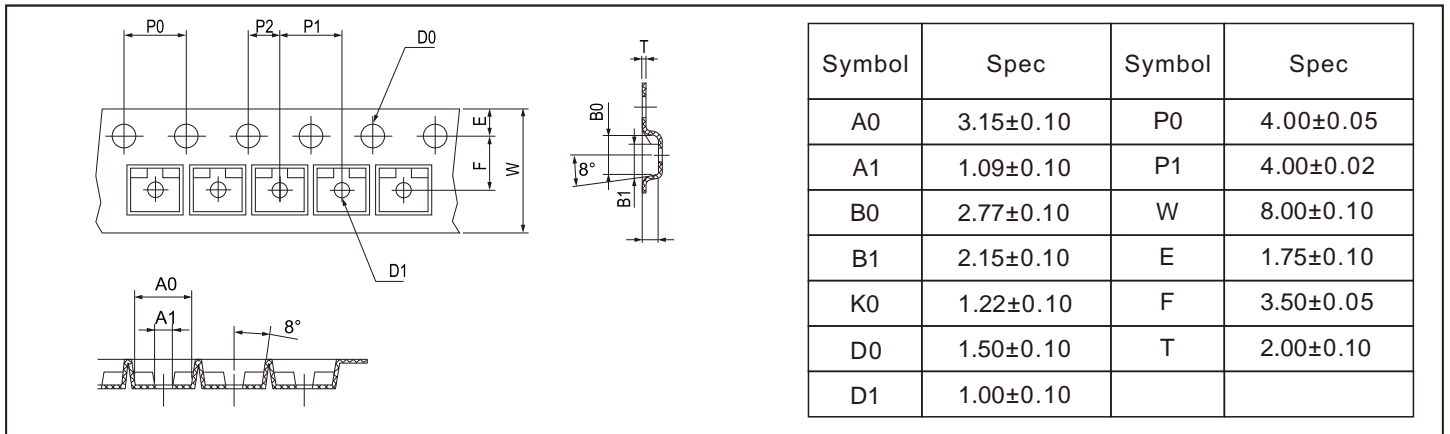

Reel Dimensions

Unit : mm

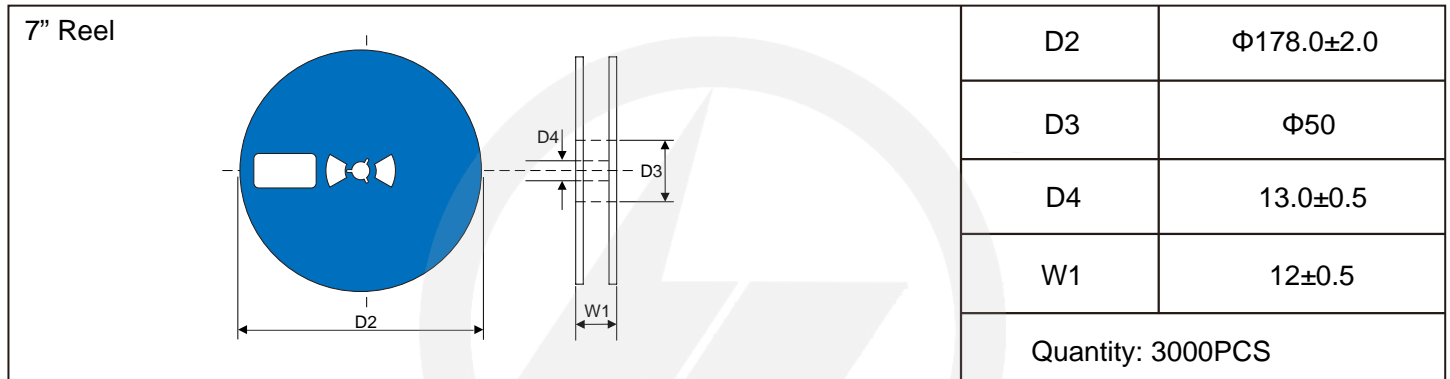

Reel Dimensions

Unit : mm

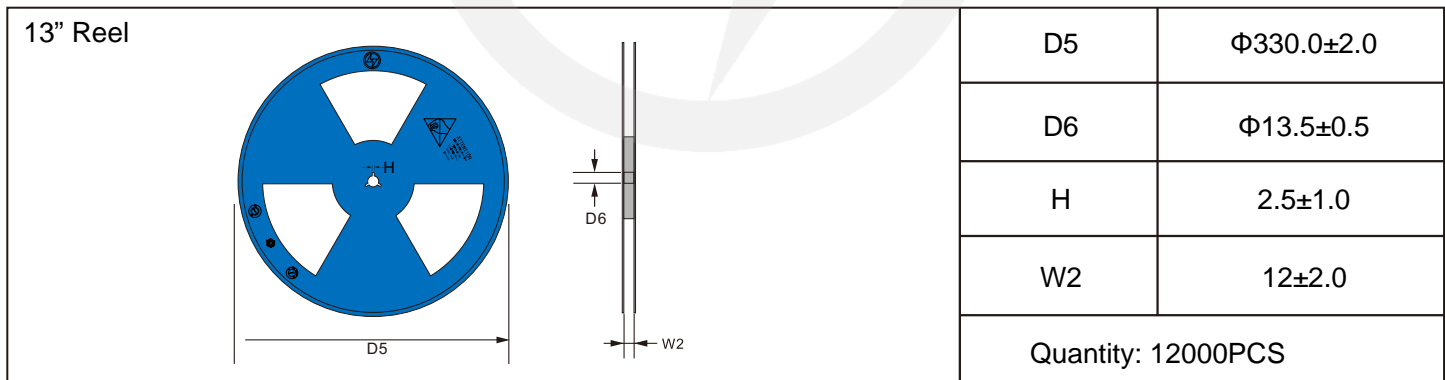

Packaging

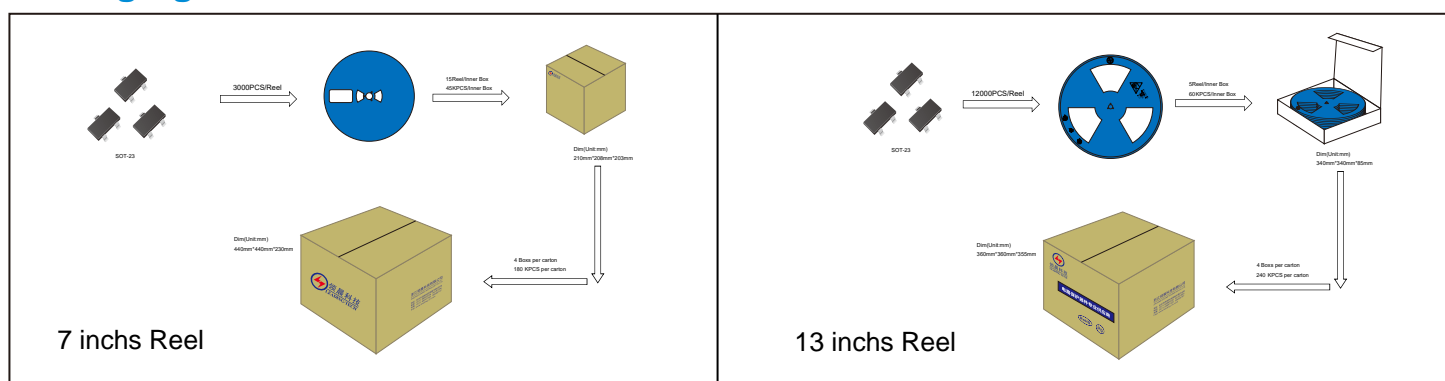



Recommended Soldering Conditions

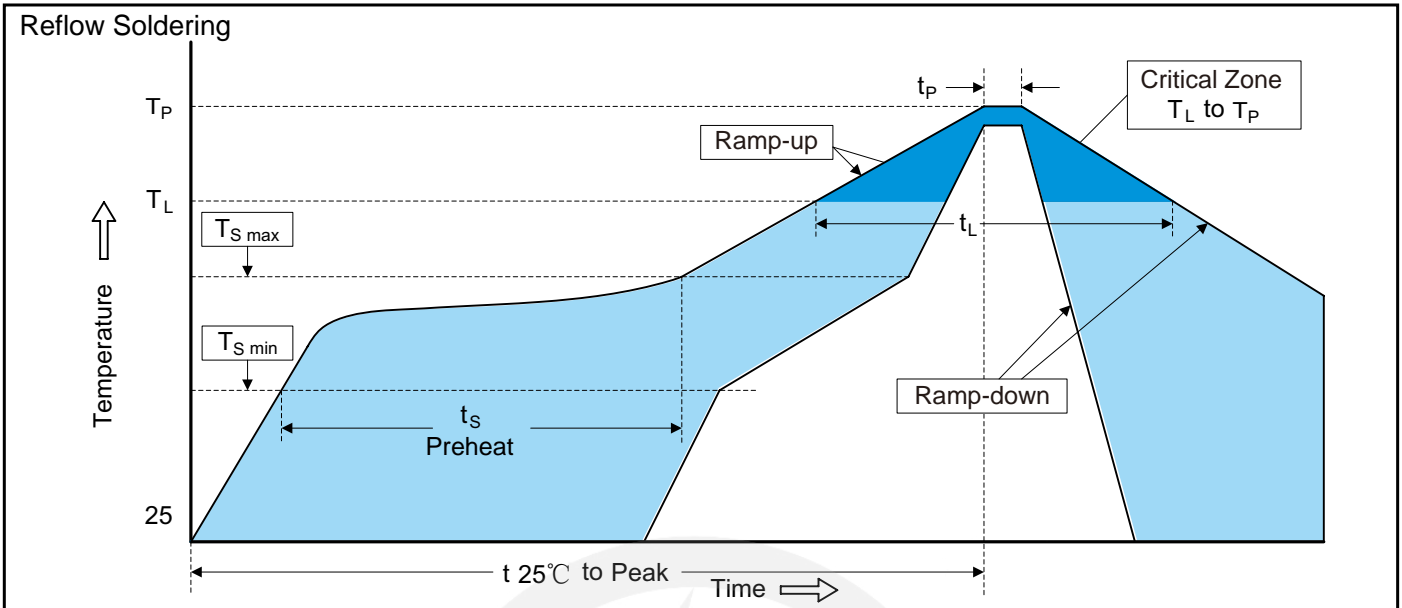

Recommended Conditions

Profile Feature	Pb-Free Assembly
Average ramp-up rate (T _L to T _P)	3°C/second max.
Preheat	
-Temperature Min (T _{S min})	150°C
-Temperature Max (T _{S max})	200°C
-Time (min to max) (t _s)	60-180 seconds
T _{S max} to T _L	
-Ramp-up Rate	3°C/second max.
Time maintained above:	
-Temperature (T _L)	217°C
-Time (t _L)	60-150 seconds
Peak Temperature (T _P)	260°C
Time within 5°C of actual Peak Temperature (t _p)	20-40 seconds
Ramp-down Rate	6°C/second max.
Time 25°C to Peak Temperature	8 minutes max.

Important Notice and Disclaimer

Leading-Tech reserves the right to make changes to this document and its products and specifications at any time without notice.

Customers should obtain and confirm the latest product information and specifications before final design, purchase or use.

Leading-Tech makes no warranty, representation or guarantee regarding the suitability of its products for any particular purpose, not does Leading-Tech assume any liability for application assistance or customer product design.

Leading-Tech does not warrant or accept any liability with products which are purchase or used for any unintended or unauthorized application.

No license is granted by implication or otherwise under any intellectual property rights of Leading-Tech.

Leading-Tech products are not authorized for use as critical components in life support devices or systems without express written approval of Leading-Tech.

Version Update Information

Series NO.	Enactment/Revision Date	Effective Date	Version	Revision Content	Revision Reason	Revision Person	Note
01	2024.05.27	2024.05.27	3.0	New file	/	Ding	
02	2026.03.06	2026.03.06	3.1	Package outline E1(max)=2.6mm	/	Ding	