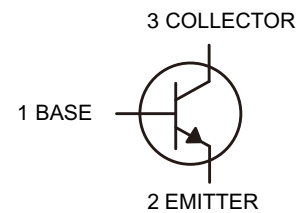
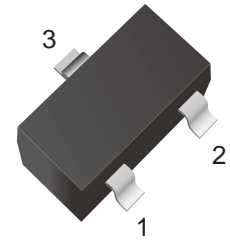

Transistor(NPN)
Features

- Low Cob:Cob=2.0pF(Typ)
- Lead free in comply with EU RoHS 2011/65/EU directives

Ordering Information

Part Number	Shipping	Reel
LT2C4617-TR3	3000PCS Tape&Reel	7 inches
LT2C4617-TR8	8000PCS Tape&Reel	7 inches

Maximum Ratings (Ta=25°C unless otherwise noted)

Symbol	Parameter	Value	Unit
V _{CB0}	Collector-Base Voltage	50	V
V _{CEO}	Collector-Emitter Voltage	50	V
V _{EBO}	Emitter-Base Voltage	5	V
I _C	Collector Current -Continuous	100	mA
P _C	Collector Power Dissipation	150	mW
T _J , T _{stg}	Operation Junction and Storage Temperature Range	-55-150	°C

Electrical Characteristics (Ta=25°C unless otherwise specified)

Parameter	Symbol	Test condition	Min	Typ	Max	Unit
Collector-base breakdown voltage	V _{(BR)CBO}	I _C =50uA, I _E =0	50			V
Collector-emitter breakdown voltage	V _{(BR)CEO}	I _C =1mA, I _B =0	50			V
Emitter-base breakdown voltage	V _{(BR)EBO}	I _E =50uA, I _C =0	5			V
Collector cut-off current	I _{CBO}	V _{CB} =50V, I _E =0			0.1	μA
Emitter cut-off current	I _{EBO}	V _{EB} =5V, I _C =0			0.1	μA
DC current gain	h _{FE}	V _{CE} =6V, I _C =1mA	120		560	
Collector-emitter saturation voltage	V _{CE(sat)}	I _C =50mA, I _B =5mA			0.4	V
Transition frequency	f _T	V _{CE} =5V, I _C =10mA, f=30MHz		280		MHz
Collector output capacitance	C _{ob}	V _{CB} =12V, I _E =0, f=1MHz		2		pF

Classification Of h_{FE}

Rank	Q	R	S
Range	120-270	180-390	270-560
Marking	BQ	BR	BS



Characteristics Curves

Fig.1 I_c vs V_{CE}

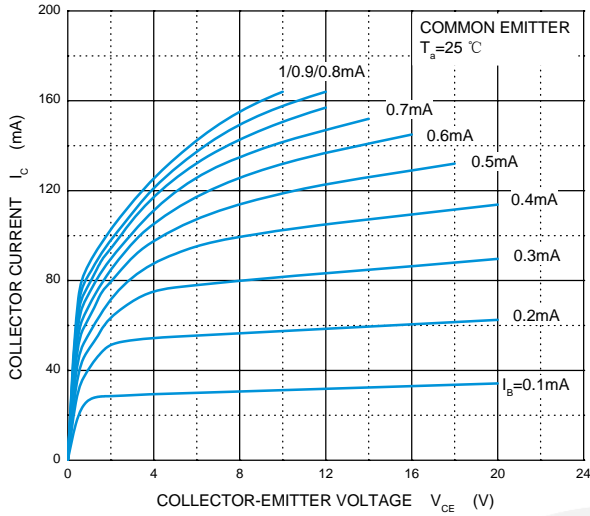

Fig.2 h_{FE} vs I_c

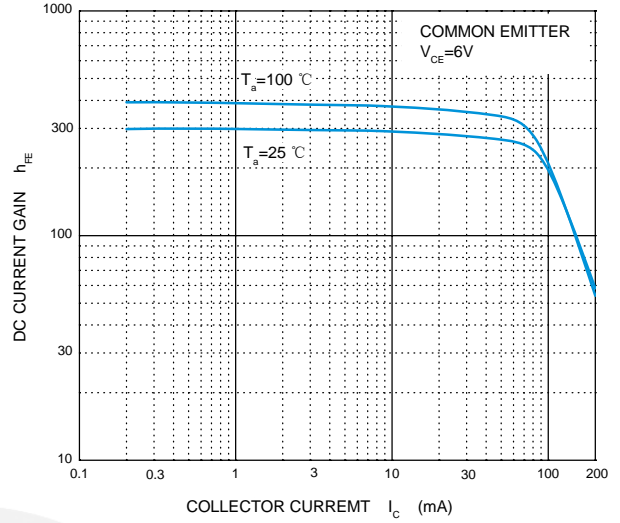

Fig.3 V_{CEsat} vs I_c

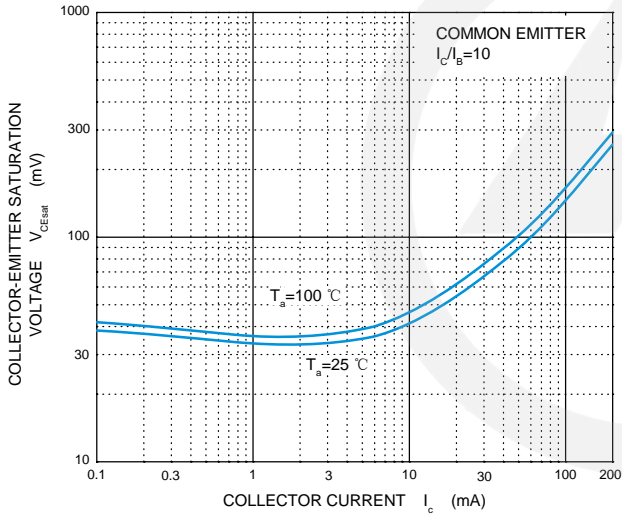

Fig.4 I_c vs V_{BE}

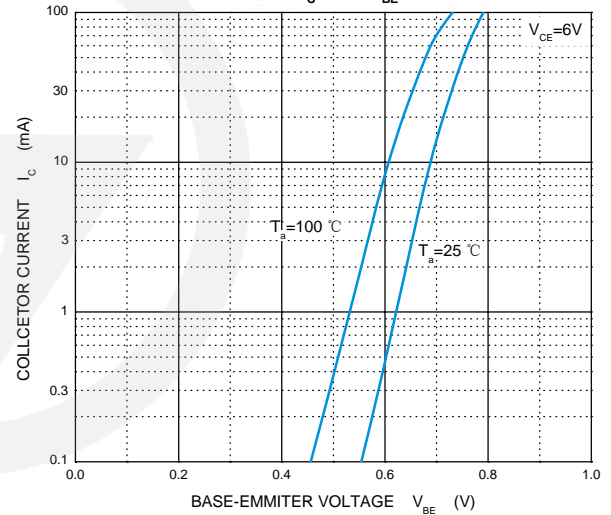

Fig.5 C_{ob}/C_{ib} vs V_{CB}/V_{EB}

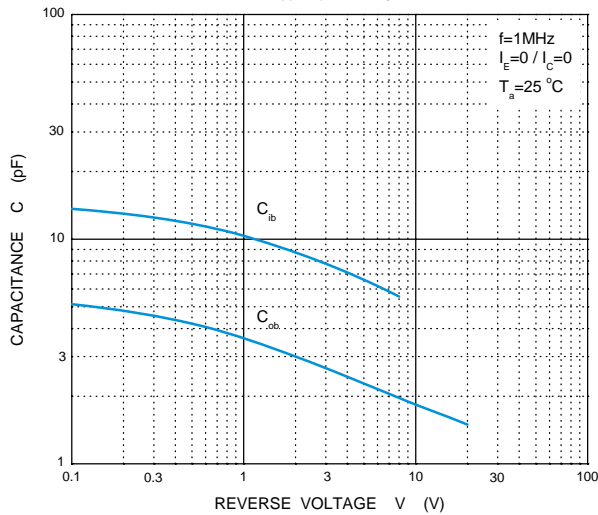
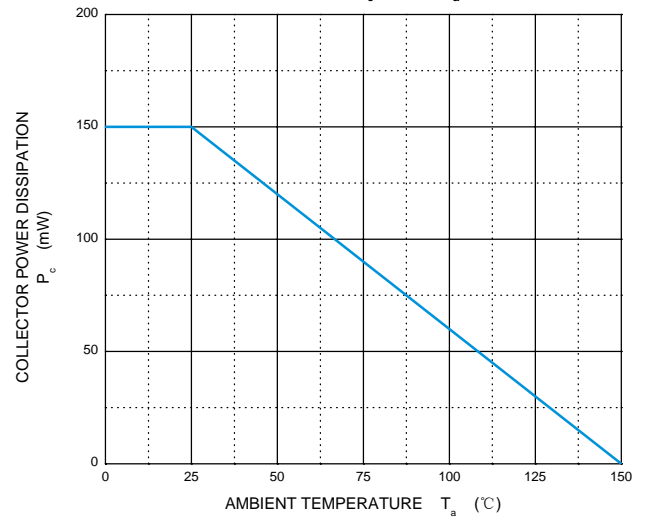
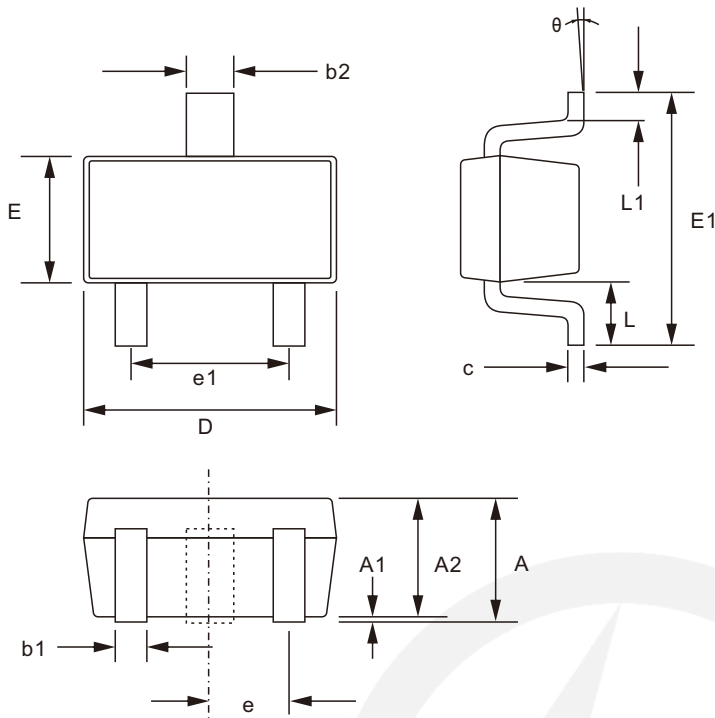

Fig.6 P_c vs T_a



SOT-523 Package Outline



Unit: mm

SYMBOL	DIMENSIONS	
	MIN.	MAX.
A	0.70	0.90
A1	0.00	0.10
A2	0.70	0.80
b1	0.15	0.25
b2	0.25	0.35
c	0.10	0.20
D	1.50	1.70
E	0.70	0.90
E1	1.45	1.75
e	0.50 TYP.	
e1	0.90	1.10
L	0.40 TYP.	
L1	0.10	0.30
θ	0°	8°

SOT-523 Suggested Pad Layout

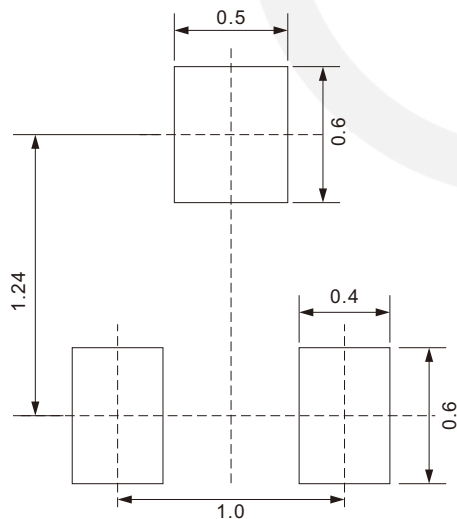

Note:

1. Controlling dimension: in millimeters.
2. General tolerance: $\pm 0.05\text{mm}$
3. The pad layout is for reference purpose only.

Carrier Tape Diemensions

Unit : mm

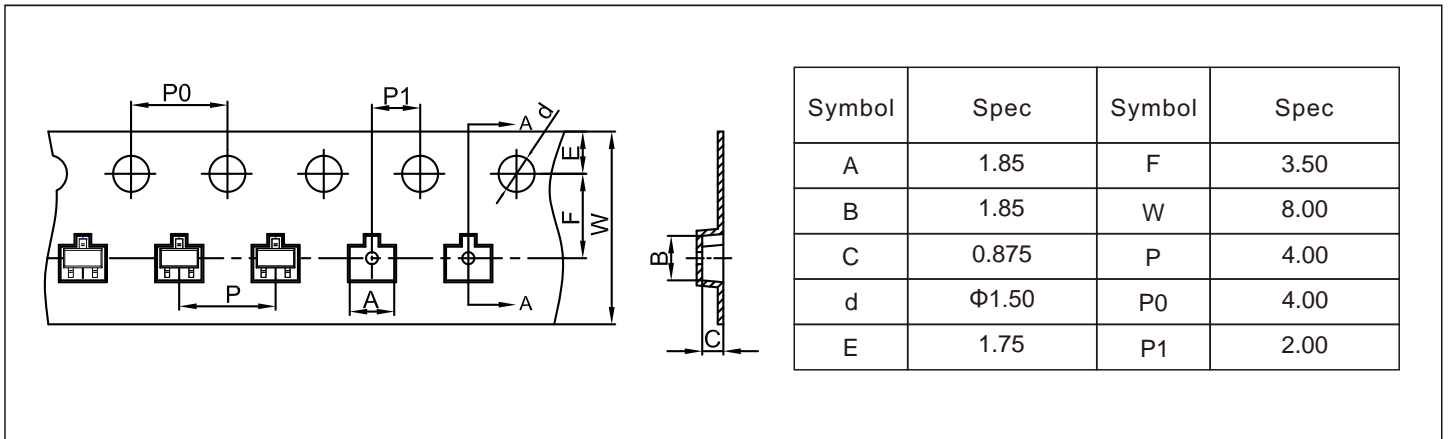

Reel Diemensions

Unit : mm

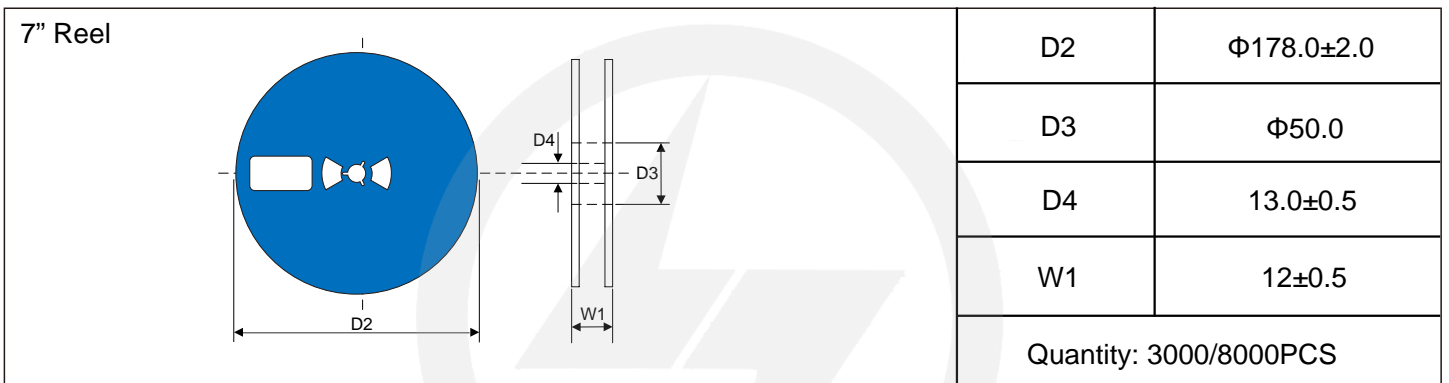

Packaging

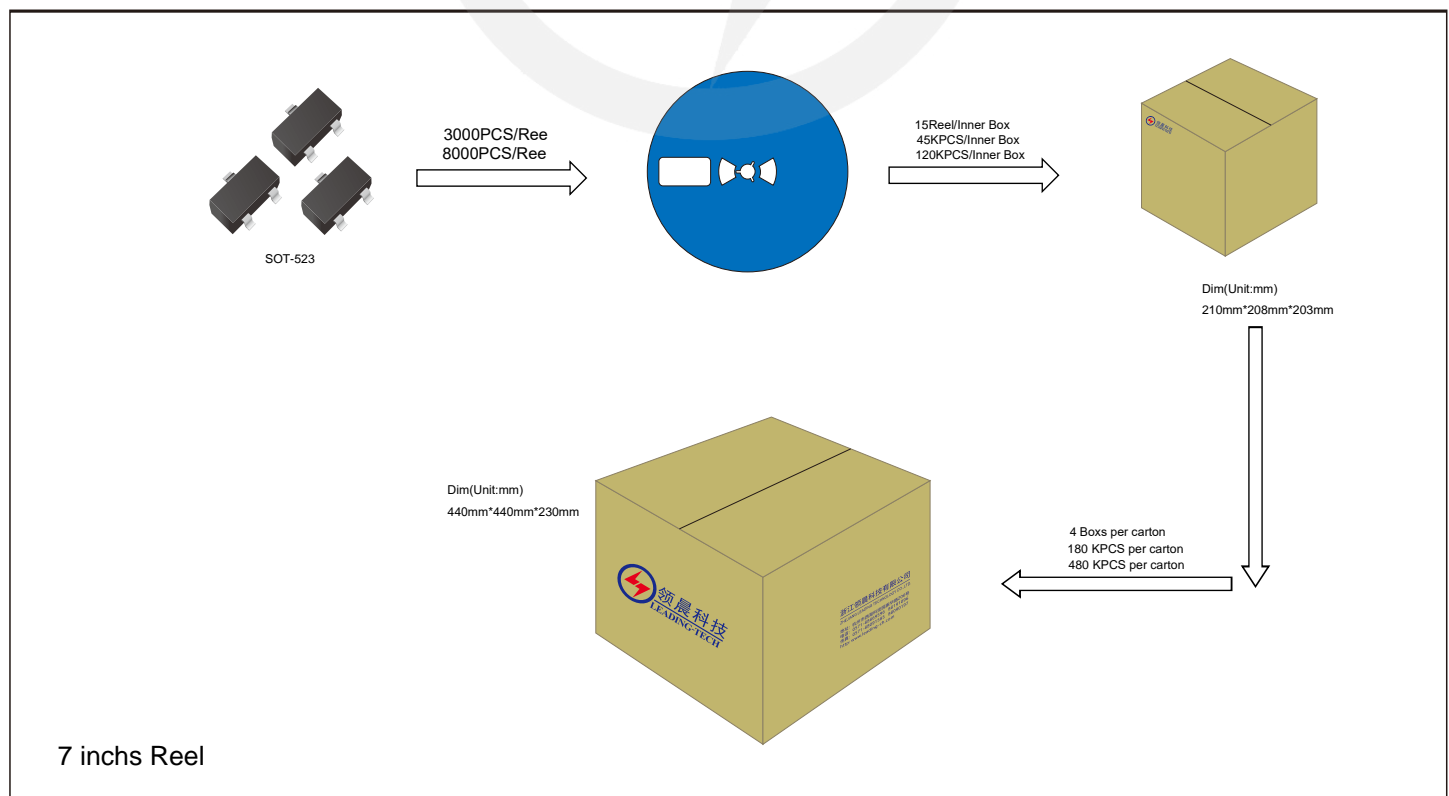

7 inches Reel



Recommended Soldering Conditions

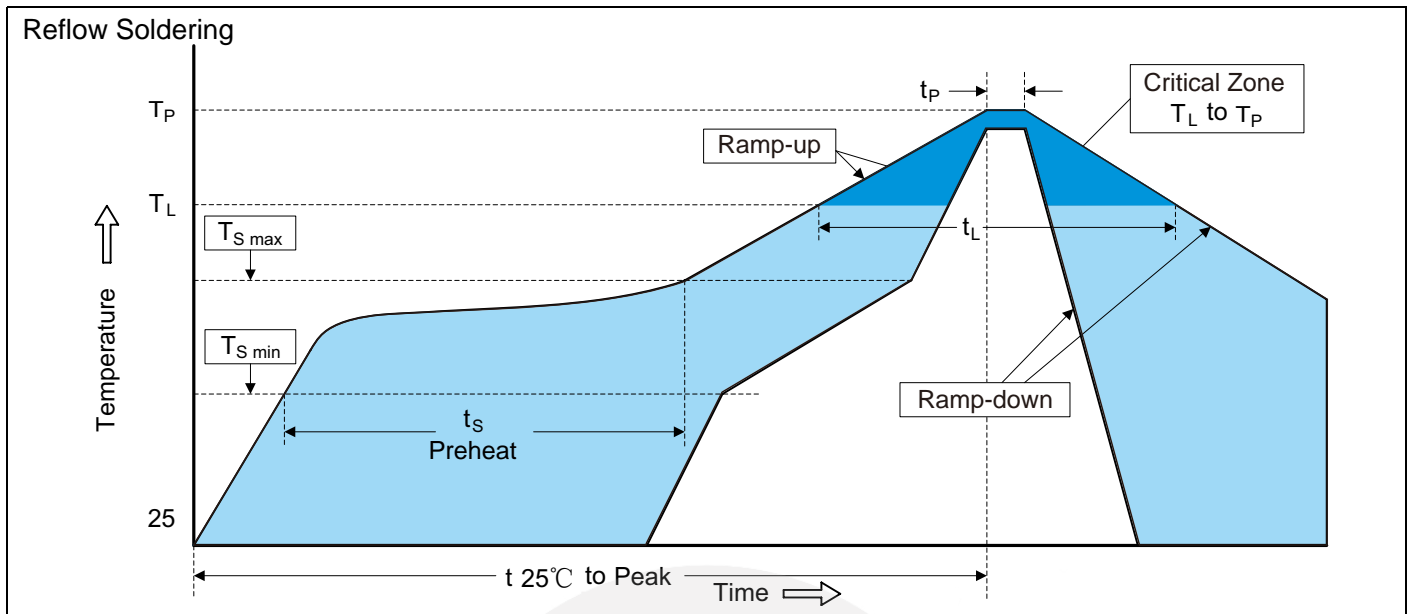

Recommended Conditions

Profile Feature	Pb-Free Assembly
Average ramp-up rate (T _L to T _P)	3°C/second max.
Preheat -Temperature Min (T _{S min}) -Temperature Max (T _{S max}) -Time (min to max) (t _s)	150°C 200°C 60-180 seconds
T _{S max} to T _L -Ramp-up Rate	3°C/second max.
Time maintained above: -Temperature (T _L) -Time (t _L)	217°C 60-150 seconds
Peak Temperature (T _P)	260°C
Time within 5°C of actual Peak Temperature (t _p)	20-40 seconds
Ramp-down Rate	6°C/second max.
Time 25°C to Peak Temperature	8 minutes max.

Important Notice and Disclaimer

Leading-Tech reverses the right to make changes to this document and its products and specifications at any time without notice.

Customers should obtain and confirm the latest product information and specifications before final design, purchase or use.

Leading-Tech makes no warranty, representation or guarantee regarding the suitability of its products for any particular purpose, not does Leading-Tech assume any liability for application assistance or customer product design.

Leading-tech does not warrant or accept any liability with products which are purchase or used for any unintended or unauthorized application.

No license is granted by implication or otherwise under any intellectual property rights of Leading-Tech.

Leading-Tech products are not authorized for use as critical components in life support devices or systems without express written approval of Leading-tech.

Version Update Information

Series NO.	Enactment/Revision Date	Effective Date	Version	Revision content	Revision Reason	Revision Person	Note
01	2024.4.5	2024.4.5	3.0	New File	/	Ding	