

Transistor(PNP)
Features

- Low $V_{CE(sat)}$
- High breakdown voltage
- Lead free in comply with EU RoHS 2011/65/EU directives

Mechanical Data

- Case:SOT-23
- Approx. Weight: 8.1mg

Ordering Information

Part Number	Marking	Shipping	Reel
LT2B1198-TR3	AKR	3000PCS Tape&Reel	7 inches
LT2B1198-TR12	AKR	12000PCS Tape&Reel	13 inches

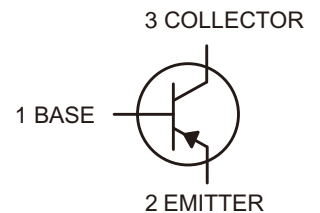
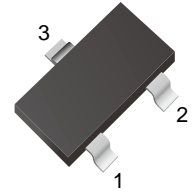
Maximum Ratings ($T_a=25$ unless otherwise noted)

Parameter	Symbol	Value	Unit
Collector–Base Voltage	V_{CBO}	-80	V
Collector–Emitter Voltage	V_{CEO}	-80	V
Emitter – Base Voltage	V_{EBO}	-5	V
Collector Current — Continuous	I_c	-500	mA
Collector Power Dissipation	P_c	200	mW
Operation Junction and Storage Temperature Range	T_J, T_{stg}	-55 to +150	°C

Electrical Characteristics ($T_a=25$ unless otherwise specified)

Parameter	Symbol	Test conditions	Min	Typ	Max	Unit
Collector-base breakdown voltage	$V_{(BR)CBO}$	$I_c = -50\mu A, I_E = 0$	-80			V
Collector-emitter breakdown voltage	$V_{(BR)CEO}$	$I_c = -2mA, I_B = 0$	-80			V
Emitter-base breakdown voltage	$V_{(BR)EBO}$	$I_E = -50\mu A, I_c = 0$	-5			V
Collector cut-off current	I_{CBO}	$V_{CB} = -50V, I_E = 0$			-500	nA
Emitter cut-off current	I_{EBO}	$V_{EB} = -4V, I_c = 0$			-500	nA
DC current gain	h_{FE}	$V_{CE} = -3V, I_c = -100mA$	180		390	
Collector-emitter saturation voltage	$V_{CE(sat)}$	$I_c = -500mA, I_B = -50mA$			-0.5	V
Transition frequency	f_T	$V_{CE} = -10V, I_c = -50mA, f=100MHz$		180		MHz



Characteristics Curve

Fig 1. Static characteristics

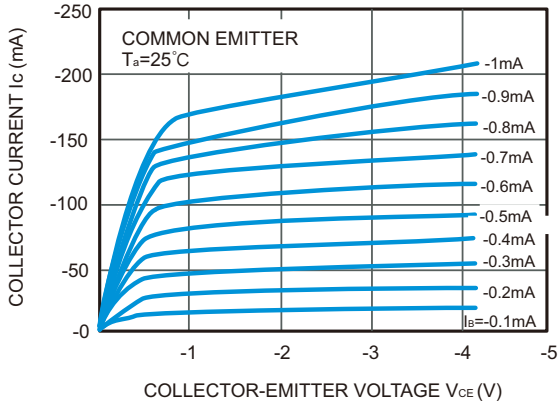

Fig 2. PC vs Ta

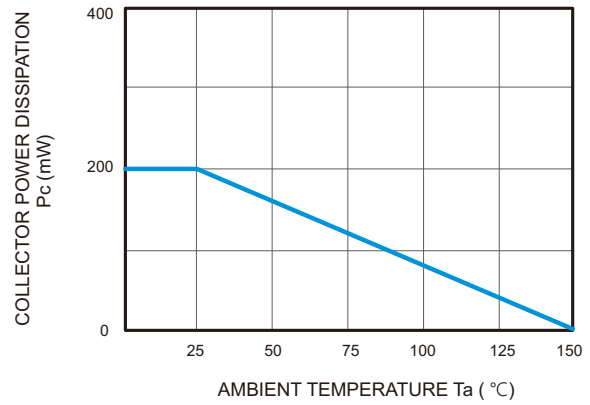

Fig 3. Cob / Cib vs VCB / VEB

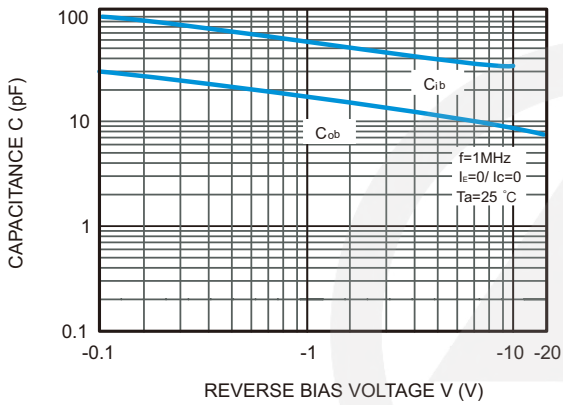

Fig 4. VCEsat vs IC

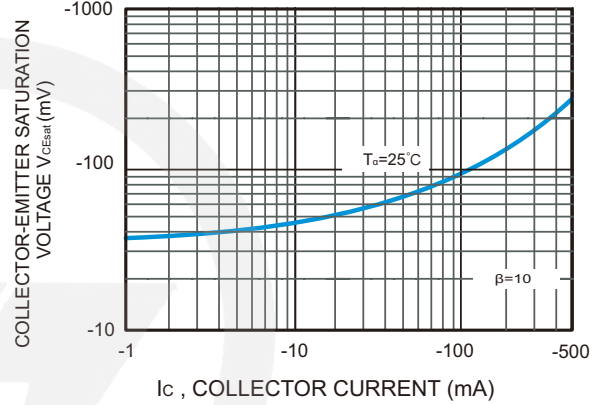

Fig 5. hFE vs IC

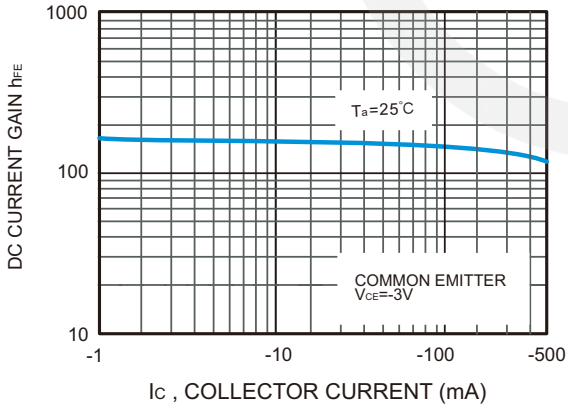

Fig 6. VBEsat vs IC

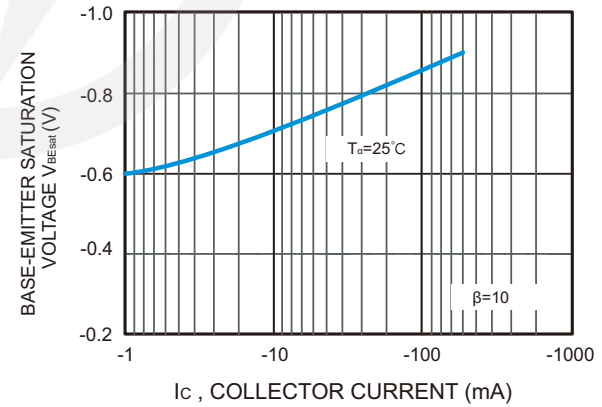

Fig 7. IC vs VBE

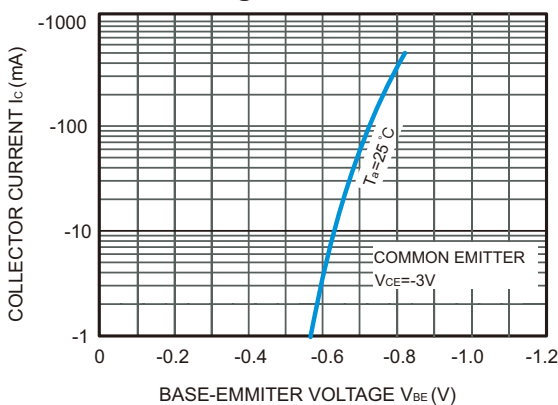
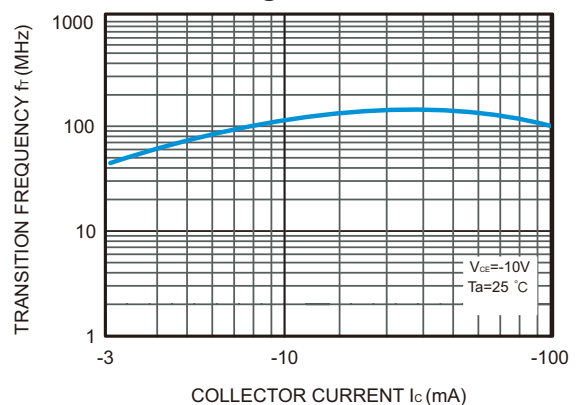

Fig 8. fT vs IC





SOT-23 Package Outline

Unit: mm

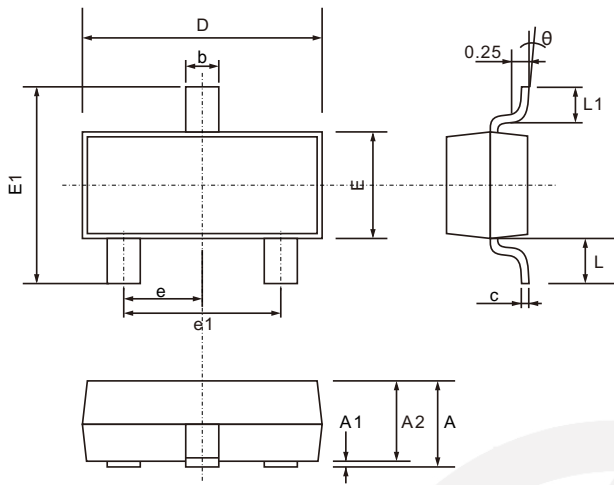

SYMBOL	DIMENSIONS	
	MIN.	MAX.
A	0.900	1.200
A1	0.000	0.100
A2	0.900	1.050
b	0.300	0.500
c	0.080	0.200
D	2.700	3.100
E	1.200	1.400
E1	2.200	2.600
e	0.950 TYP.	
e1	1.750	2.050
L	0.550 TYP.	
L1	0.300	0.500
θ	0°	8°

SOT-23 Suggested Pad Layout

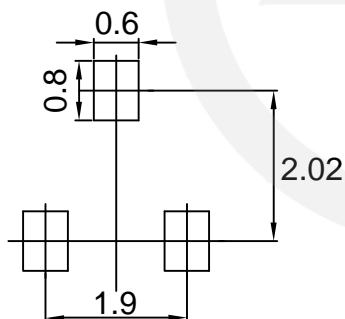

- Note:
1. Controlling dimension: in millimeters.
 2. General tolerance: $\pm 0.05\text{mm}$
 3. The pad layout is for reference purpose only.

Carrier Tape Dimensions

Unit : mm

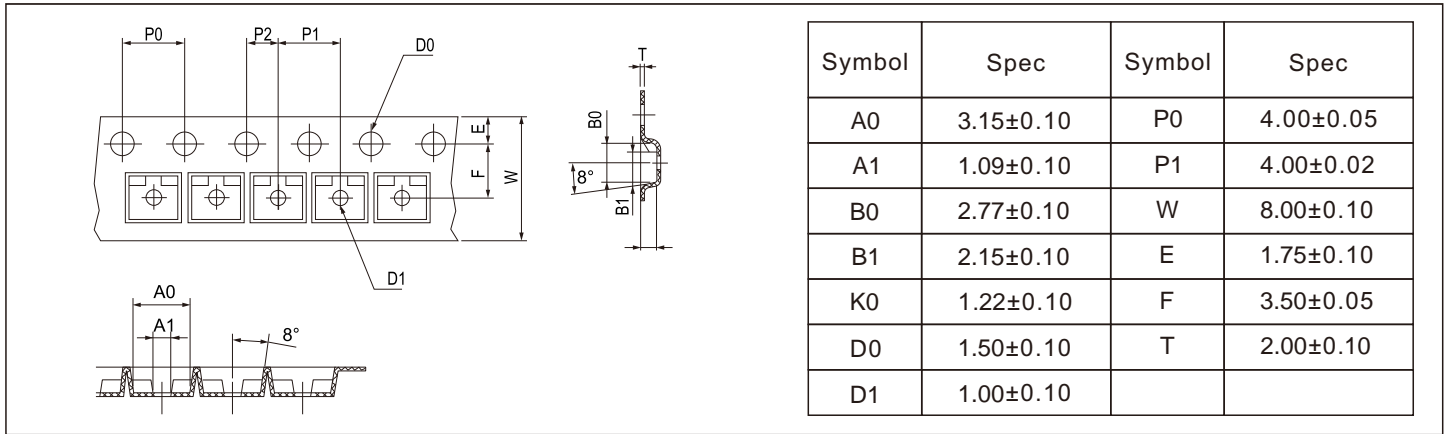

Reel Dimensions

Unit : mm

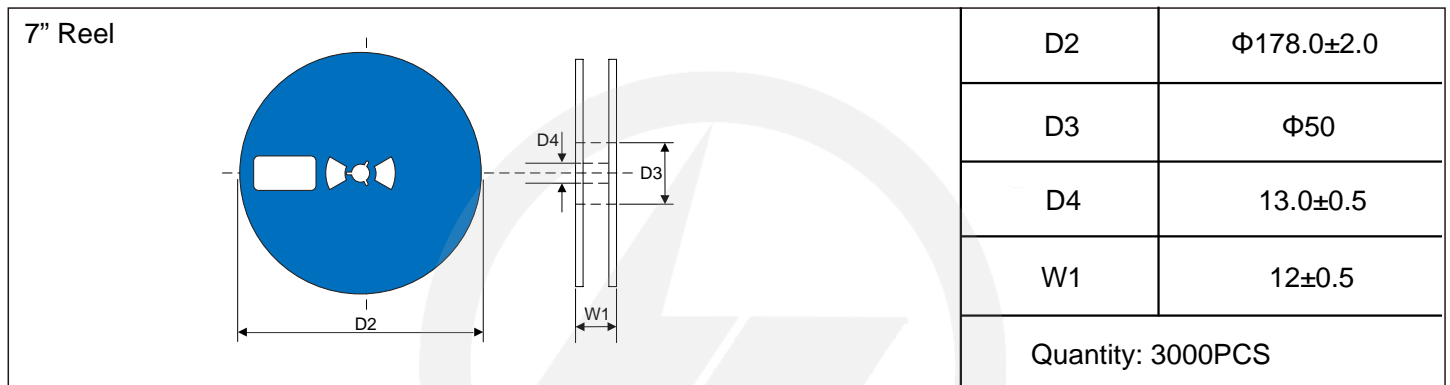

Reel Dimensions

Unit : mm

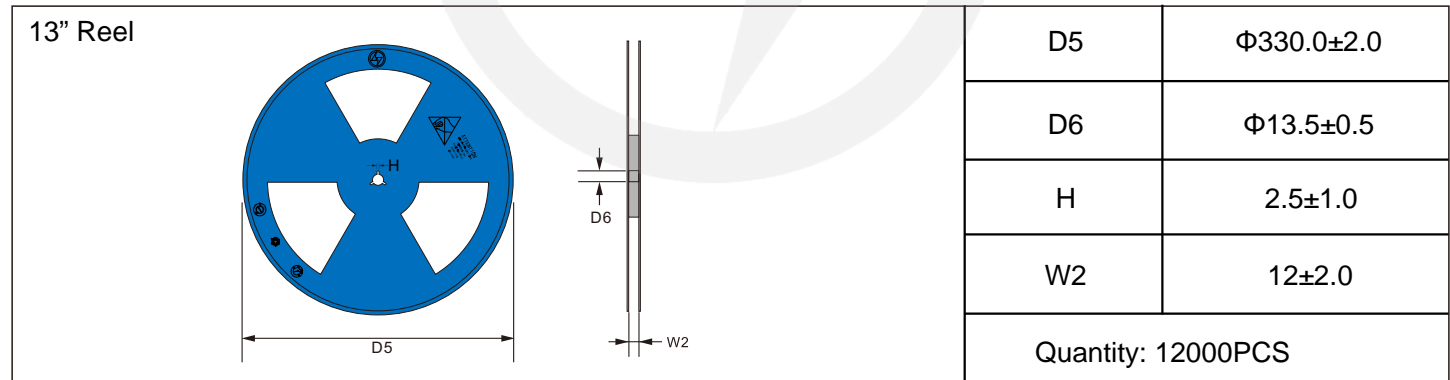

Packaging

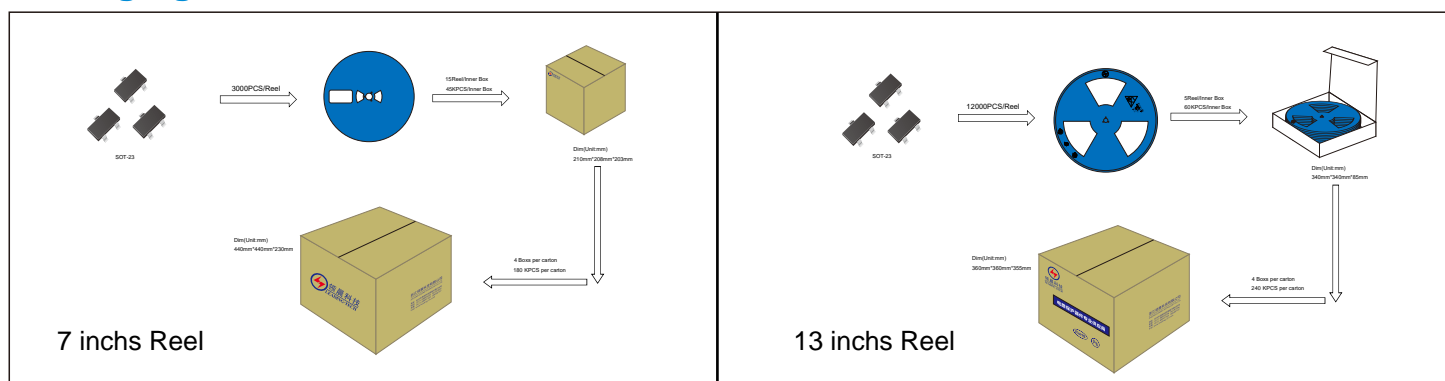



Recommended Soldering Conditions



Recommended Conditions

Profile Feature	Pb-Free Assembly
Average ramp-up rate (T _L to T _P)	3°C/second max.
Preheat	
-Temperature Min (T _{S min})	150°C
-Temperature Max (T _{S max})	200°C
-Time (min to max) (t _s)	60-180 seconds
T _{S max} to T _L	
-Ramp-up Rate	3°C/second max.
Time maintained above:	
-Temperature (T _L)	217°C
-Time (t _L)	60-150 seconds
Peak Temperature (T _P)	260°C
Time within 5°C of actual Peak Temperature (t _p)	20-40 seconds
Ramp-down Rate	6°C/second max.
Time 25°C to Peak Temperature	8 minutes max.

Important Notice and Disclaimer

Leading-Tech reserves the right to make changes to this document and its products and specifications at any time without notice.

Customers should obtain and confirm the latest product information and specifications before final design, purchase or use.

Leading-Tech makes no warranty, representation or guarantee regarding the suitability of its products for any particular purpose, not does Leading-Tech assume any liability for application assistance or customer product design.

Leading-Tech does not warrant or accept any liability with products which are purchase or used for any unintended or unauthorized application.

No license is granted by implication or otherwise under any intellectual property rights of Leading-Tech.

Leading-Tech products are not authorized for use as critical components in life support devices or systems without express written approval of Leading-Tech.

Version Update Information

Series NO.	Enactment/Revision Date	Effective Date	Version	Revision Content	Revision Reason	Revision Person	Note
01	2025.07.07	2025.07.07	3.0	New file	/	Ding	
02	2026.03.06	2026.03.06	3.1	Package outline E1(max)=2.6mm	/	Ding	