

## Switching Diodes

### Features

- Fast Switching Speed
- For General Purpose Switching Applications
- High Conductance
- Lead free in comply with EU RoHS 2011/65/EU directives

### Mechanical Data

- Case: SOT-23
- Approx. Weight: 8.1mg

### Ordering Information

Part Number	Marking	Shipping	Reel
LT23T70-TR3	A4	3000PCS Tape&Reel	7 inchs
LT23T70-TR12	A4	12000PCS Tape&Reel	13 inchs

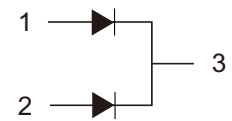
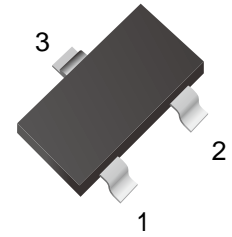

### Limiting Values (Absolute Maximum Ratings)

Parameter	Symbol	Limit	Unit
Reverse Voltage	$V_R$	100	V
Forward Current	$I_F$	200	mA
Non-Repetitive Peak Forward Surge Current @ t=8.3ms	$I_{FSM}$	2.0	A
Power Dissipation	$P_D$	225	mW
Thermal Resistance Junction to Ambient	$R_{\theta JA}$	500	°C/W
Operation Junction and Storage Temperature Range	$T_J, T_{STG}$	-55~+150	°C

### Electrical Characteristics (Ta =25°C Unless otherwise specified)

Parameter	Symbol	Min	Typ	Max	Unit	Condition
Reverse breakdown voltage	$V_R$	100			V	$I_R=100\mu A$
Forward voltage	$V_{F1}$			0.715	V	$I_F=1mA$
	$V_{F2}$			0.855	V	$I_F=10mA$
	$V_{F3}$			1	V	$I_F=50mA$
	$V_{F4}$			1.25	V	$I_F=150mA$
Reverse current	$I_R$			2.5	$\mu A$	$V_R=70V$
Capacitance between terminals	$C_T$			1.5	pF	$V_R=0, f=1MHz$
Reverse recovery time	$t_{rr}$			6	ns	$I_F = I_R = 10mA,$ $I_{rr} = 0.1 \times I_R, R_L = 100\Omega$



### Characteristics Curves

Fig.1 Forward Characteristics

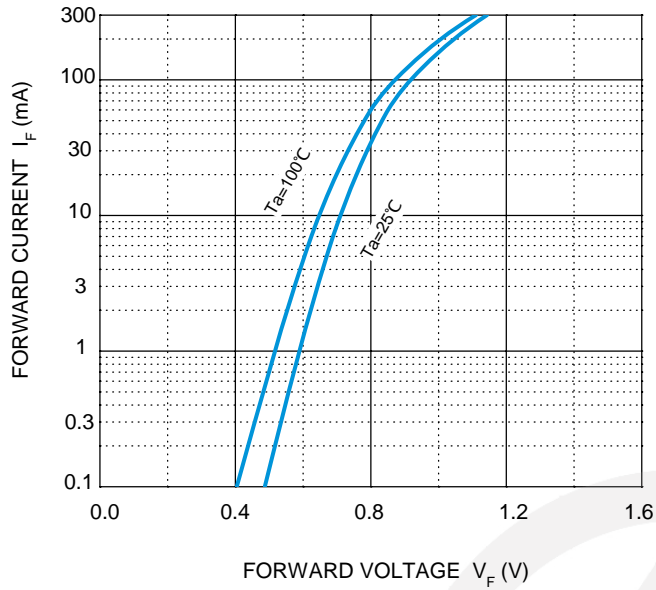

Fig.2 Typical Reverse Characteristics

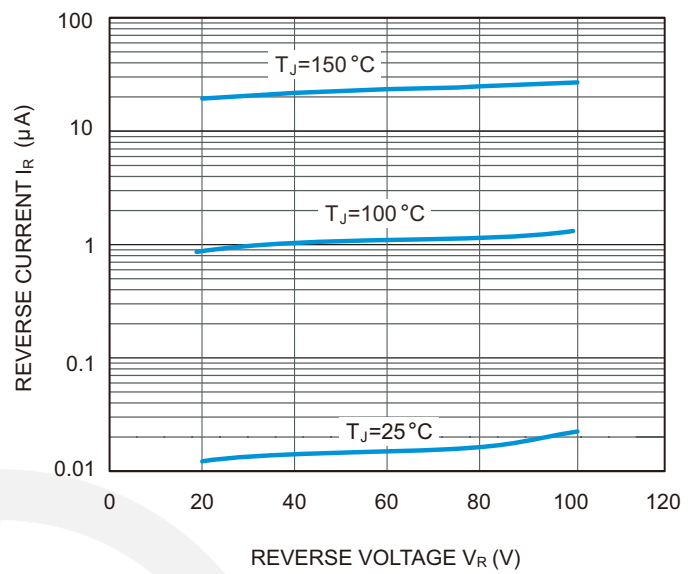

Fig.3 Capacitance Characteristics

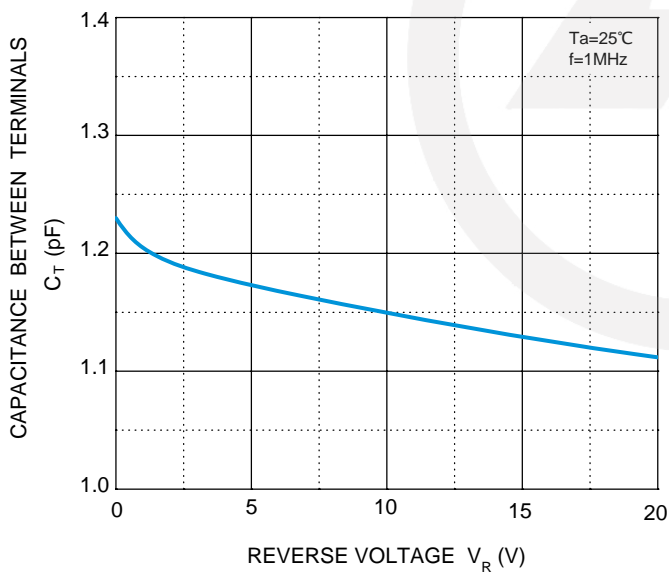
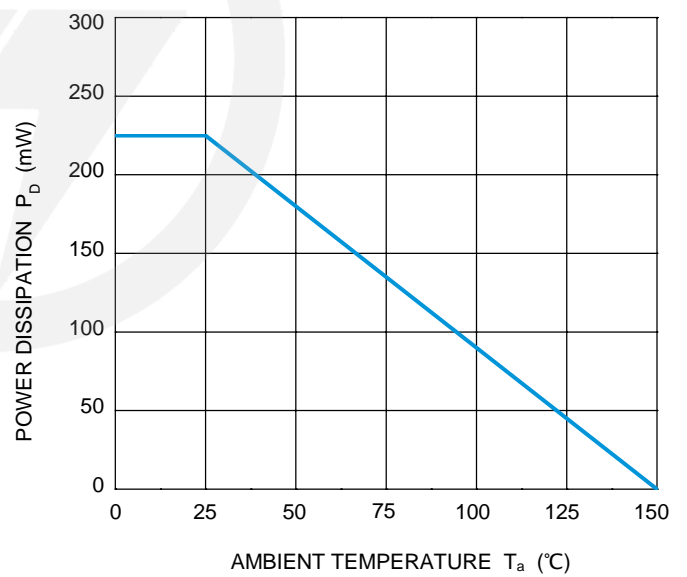
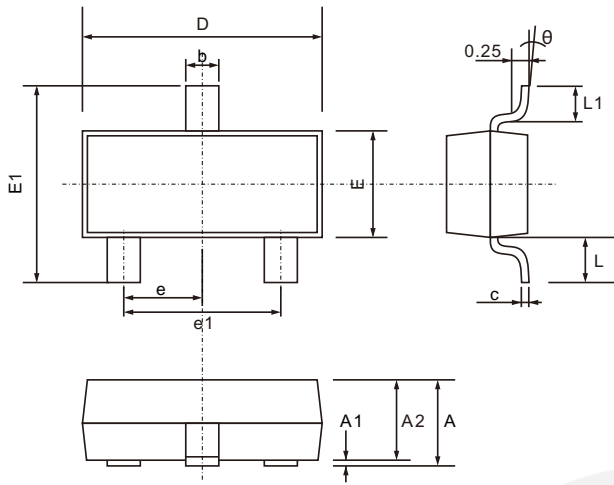

Fig.4 Power Derating Curve



**SOT-23 Package Outline**

Unit: mm



SYMBOL	DIMENSIONS	
	MIN.	MAX.
A	0.900	1.200
A1	0.000	0.100
A2	0.900	1.050
b	0.300	0.500
c	0.080	0.200
D	2.700	3.100
E	1.200	1.400
E1	2.200	2.600
e	0.950 TYP.	
e1	1.750	2.050
L	0.550 TYP.	
L1	0.300	0.500
θ	0°	8°

**SOT-23 Suggested Pad Layout**

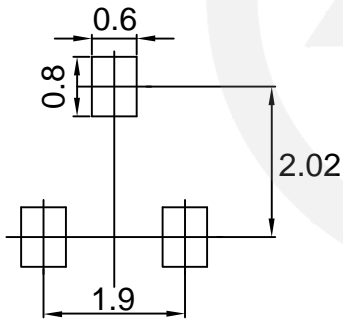

Note:  
 1. Controlling dimension: in millimeters.  
 2. General tolerance:  $\pm 0.05$ mm  
 3. The pad layout is for reference purpose only.

**Carrier Tape Dimensions**

Unit : mm

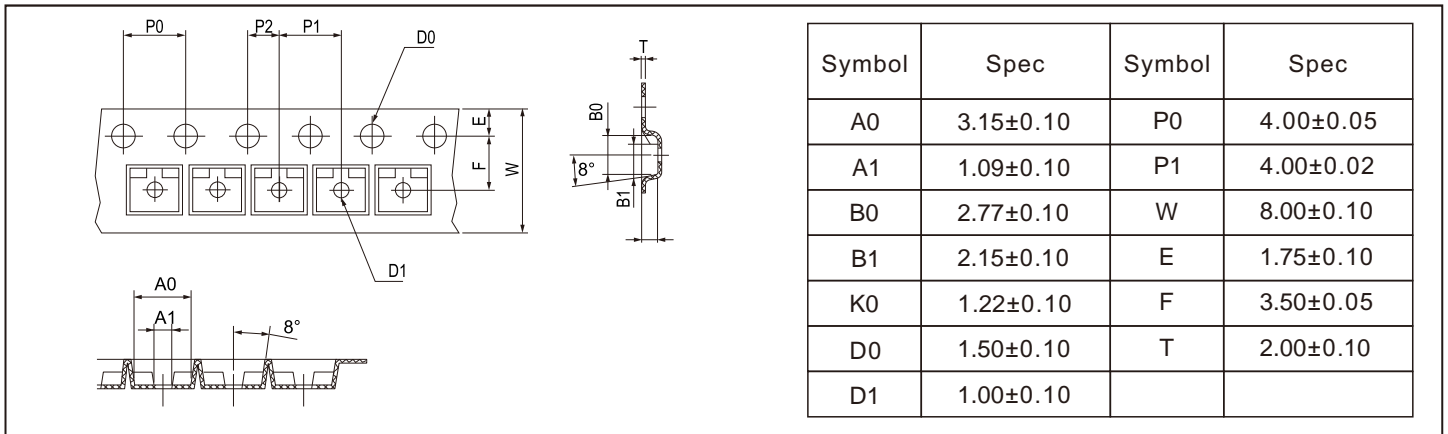

**Reel Dimensions**

Unit : mm

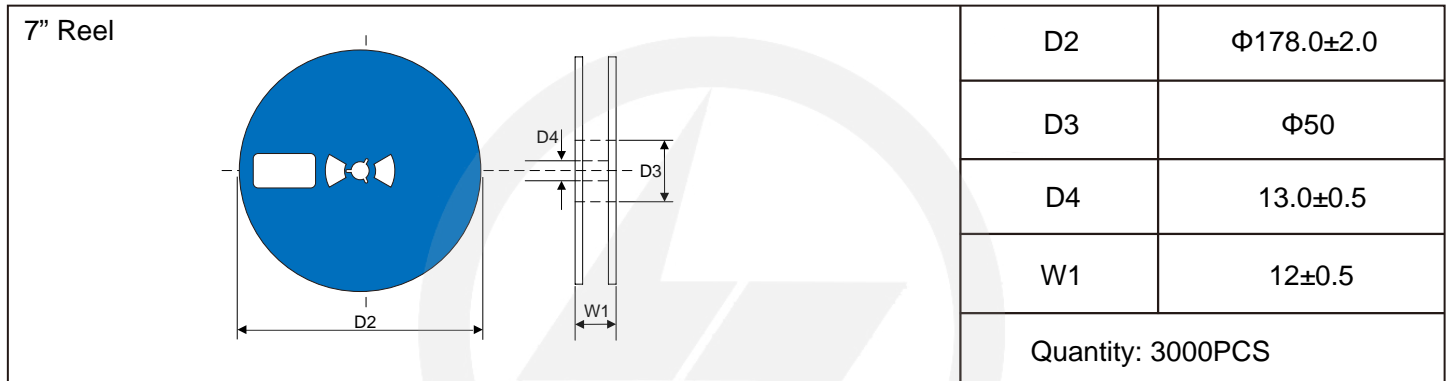

**Reel Dimensions**

Unit : mm

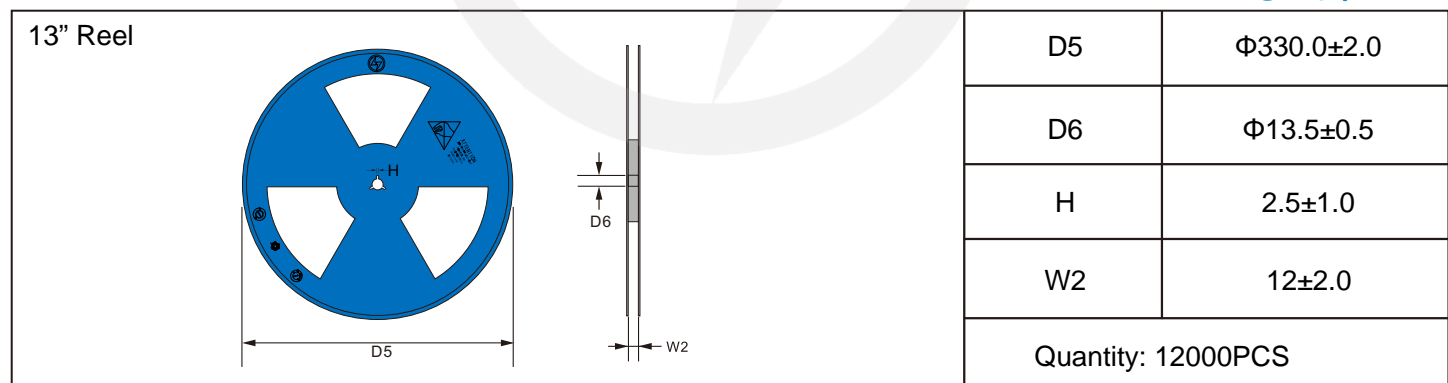

**Packaging**

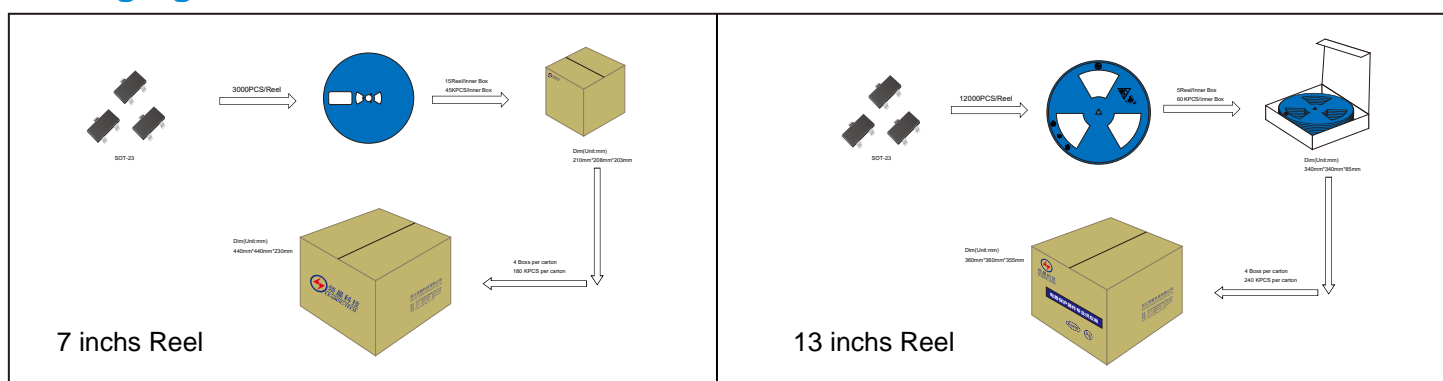



## Recommended Soldering Conditions

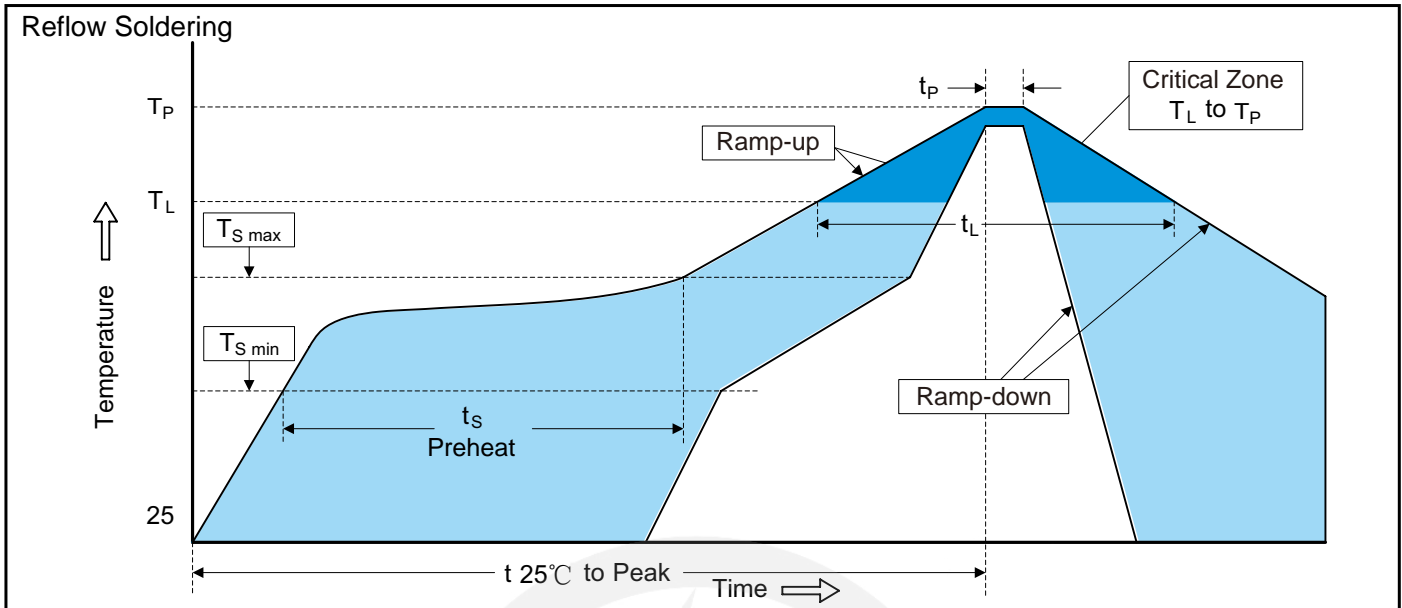

### Recommended Conditions

Profile Feature	Pb-Free Assembly
Average ramp-up rate (T <sub>L</sub> to T <sub>P</sub> )	3°C/second max.
Preheat	
-Temperature Min (T <sub>S min</sub> )	150°C
-Temperature Max (T <sub>S max</sub> )	200°C
-Time (min to max) (t <sub>s</sub> )	60-180 seconds
T <sub>S max</sub> to T <sub>L</sub>	
-Ramp-up Rate	3°C/second max.
Time maintained above:	
-Temperature (T <sub>L</sub> )	217°C
-Time (t <sub>L</sub> )	60-150 seconds
Peak Temperature (T <sub>P</sub> )	260°C
Time within 5°C of actual Peak Temperature (t <sub>p</sub> )	20-40 seconds
Ramp-down Rate	6°C/second max.
Time 25°C to Peak Temperature	8 minutes max.

## Important Notice and Disclaimer

Leading-Tech reverses the right to make changes to this document and its products and specifications at any time without notice.

Customers should obtain and confirm the latest product information and specifications before final design, purchase or use.

Leading-Tech makes no warranty, representation or guarantee regarding the suitability of its products for any particular purpose, not does Leading-Tech assume any liability for application assistance or customer product design.

Leading-Tech does not warrant or accept any liability with products which are purchase or used for any unintended or unauthorized application.

No license is granted by implication or otherwise under any intellectual property rights of Leading-Tech.

Leading-Tech products are not authorized for use as critical components in life support devices or systems without express written approval of Leading-Tech.

## Version Update Information

Series NO.	Enactment/Revision Date	Effective Date	Version	Revision Content	Revision Reason	Revision Person	Note
01	2024.03.18	2024.03.18	3.0	New file	/	Ding	
02	2025.06.18	2025.06.18	3.1	Update packaging information	/	Ding	
03	2026.03.03	2026.03.03	3.2	Add the IR curve at 150°C	/	Ding	