

N-Channel 20-V(D-S) Mosfet

Features

- Low $R_{DS(on)}$ @ $V_{GS}=4.5V$
- TrenchFET Power MOSFET
- High Current Handling Capability
- Surface Mount Package
- Lead free in comply with EU RoHS 2011/65/EU directives

Mechanical Data

- Case: SOT-23
- Approx. Weight: 8.1mg

Applications

- DC/DC Converter for Portable Devices
- Switching Circuits
- LED Driver

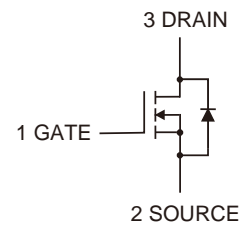
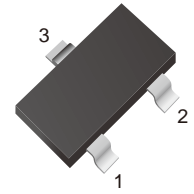

Product Summary

$V_{(BR)DSS}$	$R_{DS(on)MAX}$
20V	60m Ω @4.5V
	80m Ω @2.5V

Ordering Information

Part Number	Marking	Shipping	Reel
LT2302S-TR3	A2SHB	3000PCS Tape&Reel	7 inches
LT2302S-TR12	A2SHB	12000PCS Tape&Reel	13 inches

Maximum Ratings ($T_a=25$ unless otherwise specified)

Parameter	Symbol	Value	Unit
Drain-Source Voltage	V_{DS}	20	V
Gate-Source Voltage	V_{GS}	± 10	
Continuous Drain Current	I_D	3.2	A
Pulsed Drain Current (note1)	I_{DM}	12.8	
Maximum Power Dissipation	P_D	1	W
Thermal Resistance from Junction to Ambient (note 2)	$R_{\theta JA}$	125	$^{\circ}C/W$
Operation Junction and Storage Temperature Range	T_J, T_{STG}	-50 ~ +150	$^{\circ}C$

Electrical Characteristics (Ta=25 unless otherwise specified)

Parameter	Symbol	Test Condition	Min	Typ	Max	Units
Static						
Drain-source breakdown voltage	$V_{(BR)DSS}$	$V_{GS} = 0V, I_D = 250\mu A$	20			V
Gate-threshold voltage (note 3)	$V_{GS(th)}$	$V_{DS} = V_{GS}, I_D = 250\mu A$	0.4	0.6	1.0	
Gate-body leakage	I_{GSS}	$V_{DS} = 0V, V_{GS} = \pm 10V$			± 100	nA
Zero gate voltage drain current	I_{DSS}	$V_{DS} = 20V, V_{GS} = 0V$			1	μA
Drain-source on-resistance (note 3)	$r_{DS(on)}$	$V_{GS} = 4.5V, I_D = 3A$		0.048	0.060	Ω
		$V_{GS} = 3.3V, I_D = 2A$		0.055	0.070	
		$V_{GS} = 2.5V, I_D = 1A$		0.066	0.080	
Diode forward voltage (note 3)	V_{SD}	$I_S = 1A, V_{GS} = 0V$		0.82	1.2	V
Dynamic						
Input capacitance	C_{iss}	$V_{DS} = 10V, V_{GS} = 0V, f = 1MHz$		160		pF
Output capacitance	C_{oss}			30		
Reverse transfer capacitance	C_{rss}			25		
Switching (note 4)						
Turn-on delay time	$t_{d(on)}$	$V_{DD} = 10V, I_D \approx 2A, V_{GS} = 4.5V, R_g = 3.3\Omega$		8		ns
Rise time	t_r			30		
Turn-off delay time	$t_{d(off)}$			19		
Fall time	t_f			28		
Total gate charge	Q_g	$V_{DS} = 10V, V_{GS} = 5V, I_D = 3A$		4.0		nC
Gate-source charge	Q_{gs}			0.4		
Gate-drain charge	Q_{gd}			1.2		

***Notes :**

- 1.Repetitive rating: Pluse width limited by maximum junction temperature
- 2.Surface Mounted on FR4 board, $t \leq 10$ sec.
- 3.Pulse test : Pulse width $\leq 300\mu s$, duty cycle $\leq 2\%$.
- 4.Guaranteed by design, not subject to production.

Characteristics Curves

Fig1. Typical Output Characteristics

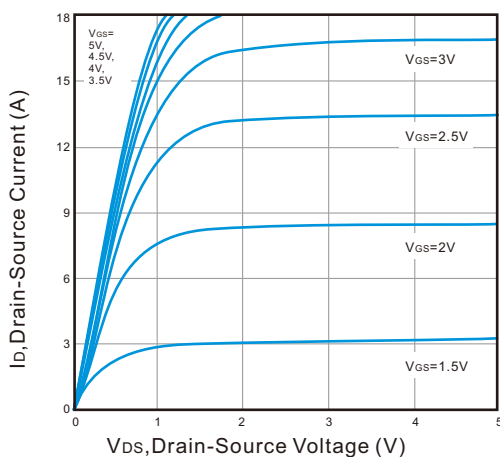

Fig2. Normalized Threshold Voltage vs. Temperature

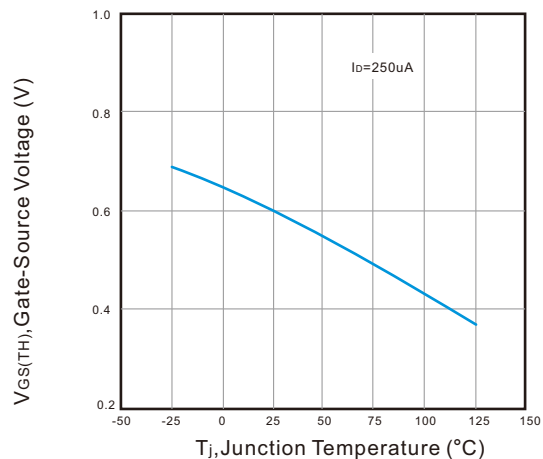



Fig 3. Typical Transfer Characteristics

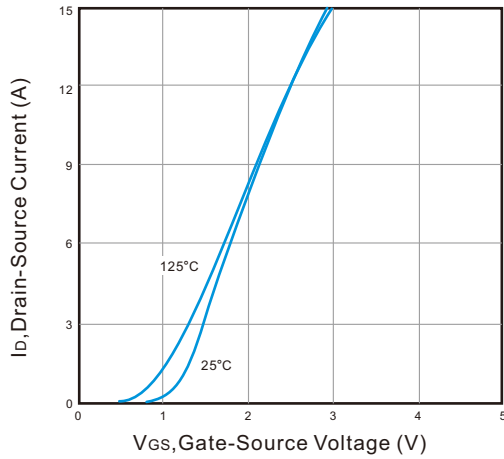

Fig 4. Drain-Source Voltage vs Gate-Source Voltage

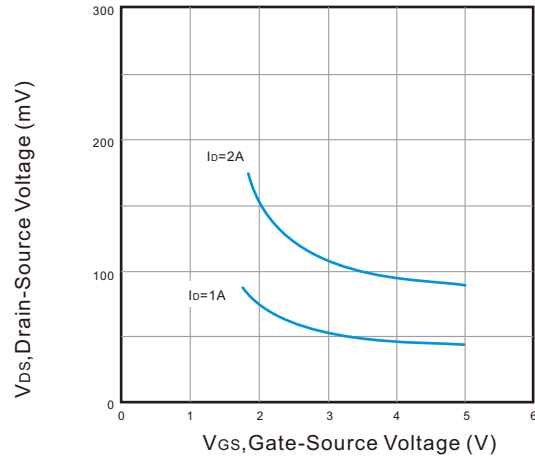

Fig 5. Typical Source-Drain Diode Forward Voltage

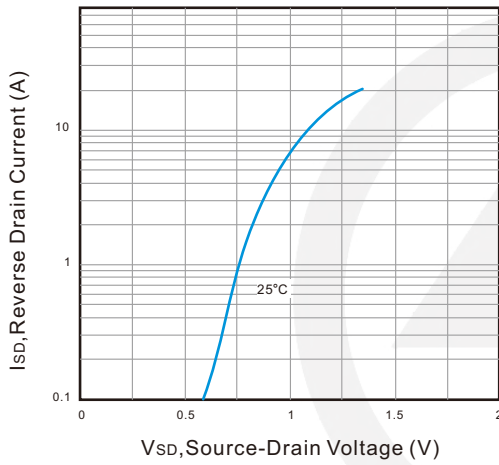

Fig 6. Maximum Safe Operating Area

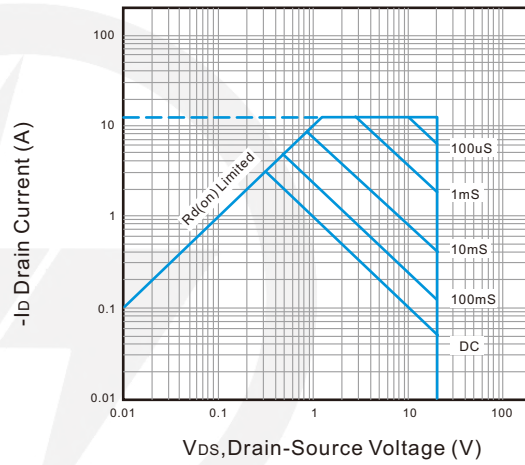

Fig 7. Typical Capacitance vs. Drain-Source Voltage

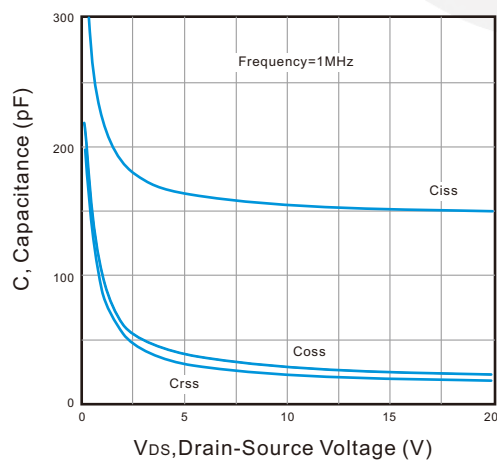
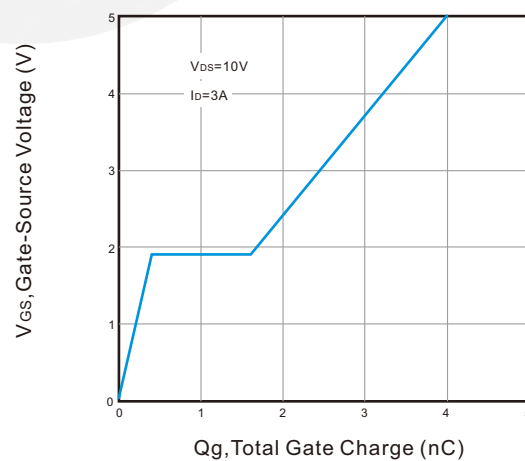
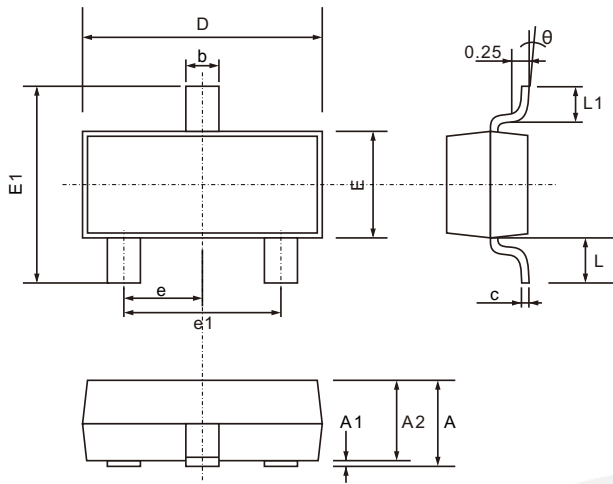

Fig 8. Typical Gate Charge vs. Gate-Source Voltage



SOT-23 Package Outline

Unit: mm



SYMBOL	DIMENSIONS	
	MIN.	MAX.
A	0.900	1.200
A1	0.000	0.100
A2	0.900	1.050
b	0.300	0.500
c	0.080	0.200
D	2.700	3.100
E	1.200	1.400
E1	2.200	2.600
e	0.950 TYP.	
e1	1.750	2.050
L	0.550 TYP.	
L1	0.300	0.500
θ	0°	8°

SOT-23 Suggested Pad Layout

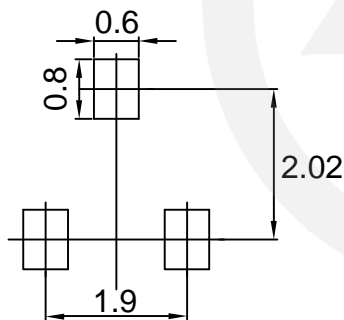

- Note:
1. Controlling dimension: in millimeters.
 2. General tolerance: $\pm 0.05\text{mm}$
 3. The pad layout is for reference purpose only.

Carrier Tape Dimensions

Unit : mm

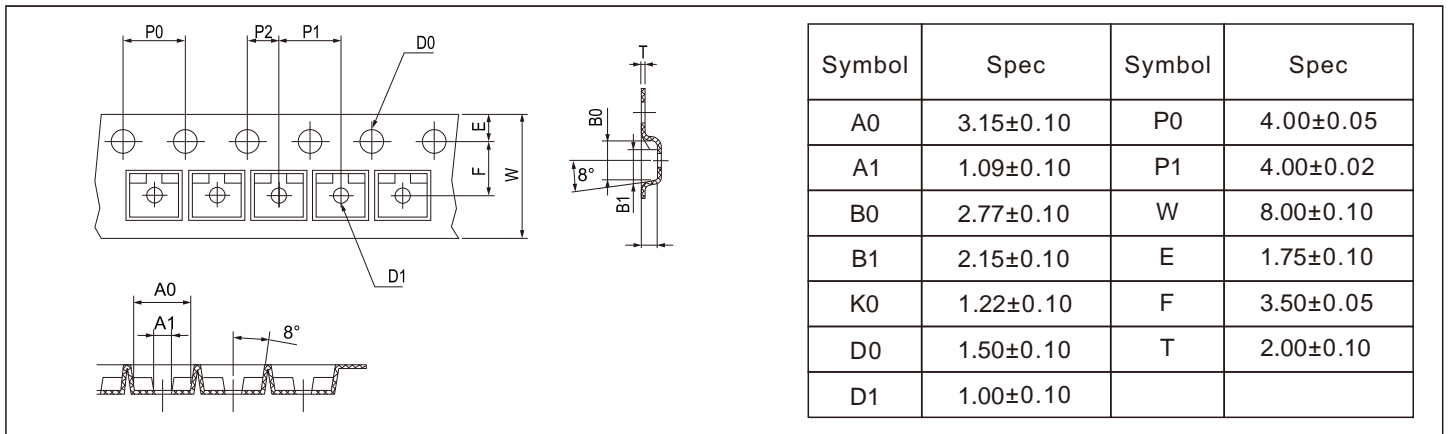

Reel Dimensions

Unit : mm

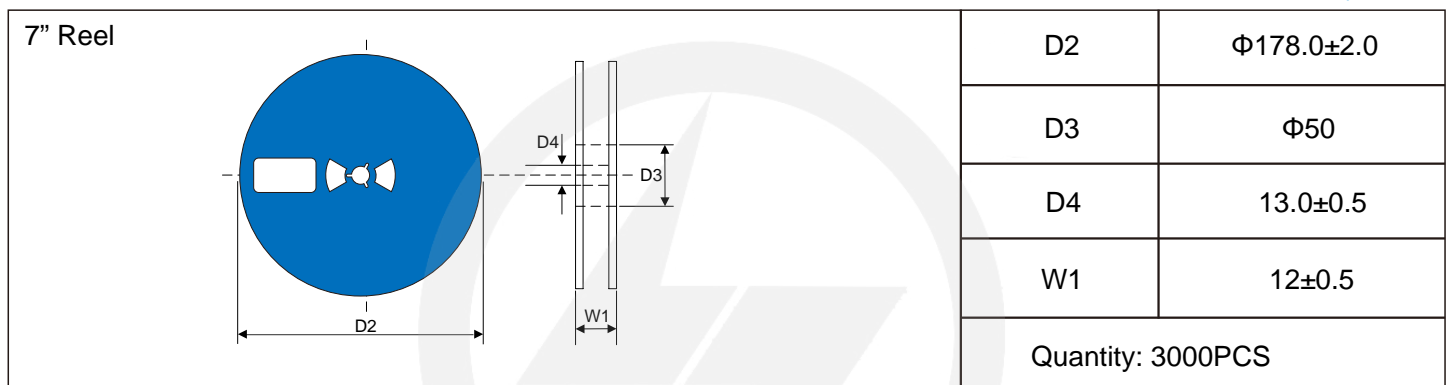

Reel Dimensions

Unit : mm

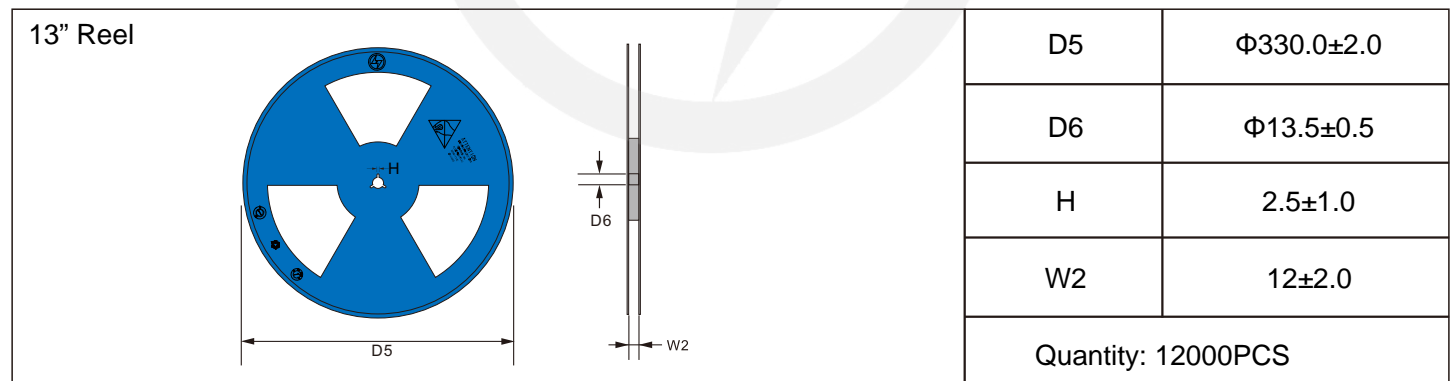

Packaging

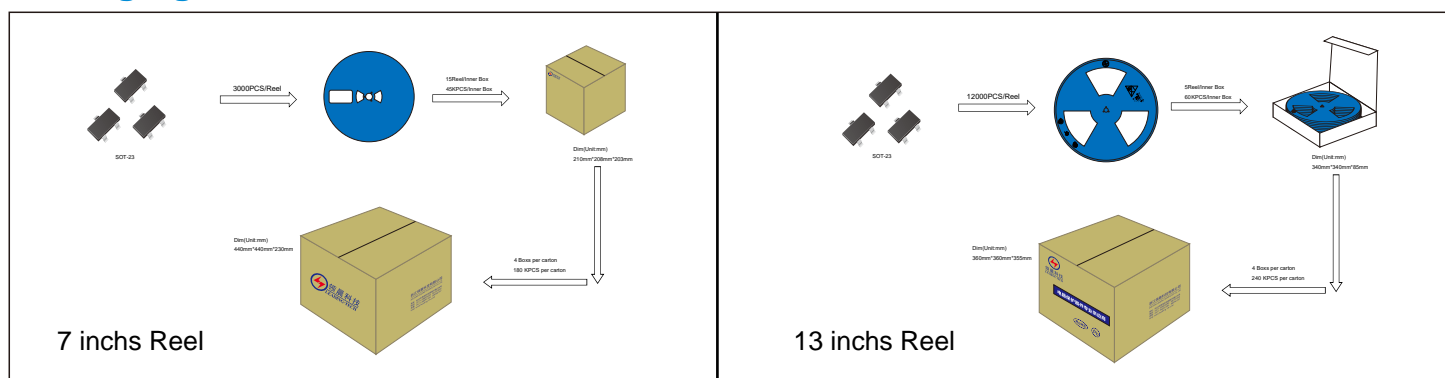



Recommended Soldering Conditions

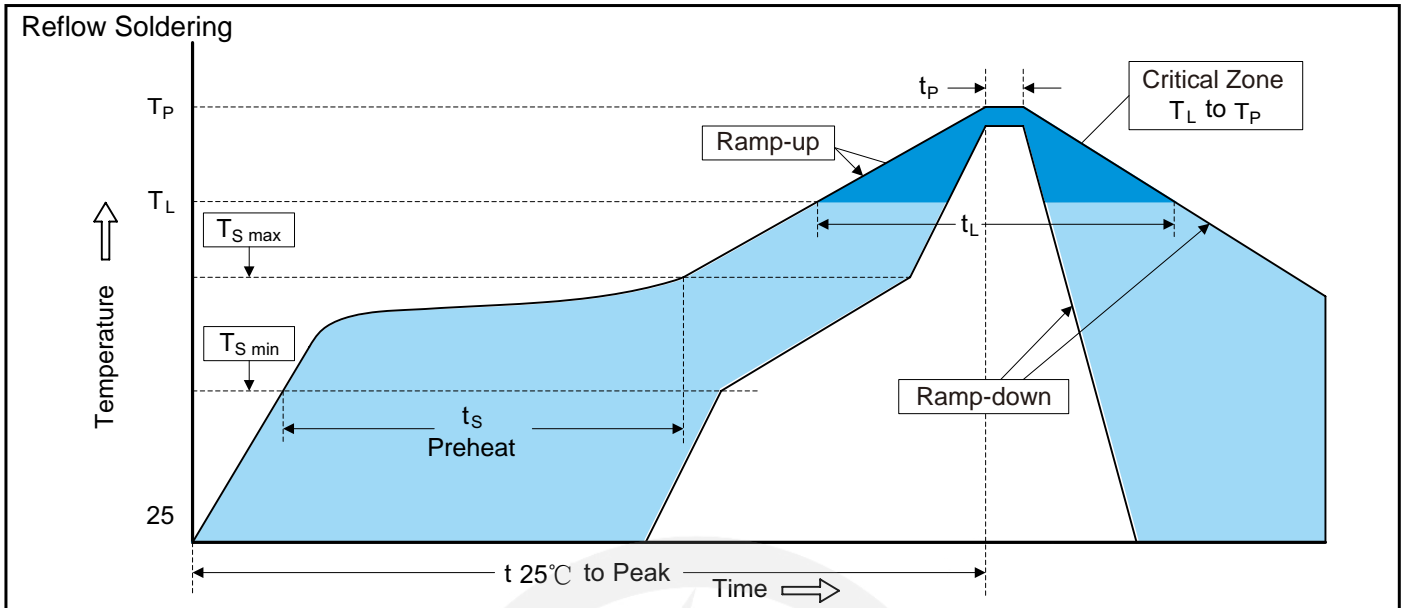

Recommended Conditions

Profile Feature	Pb-Free Assembly
Average ramp-up rate (T _L to T _P)	3°C/second max.
Preheat	
-Temperature Min (T _{S min})	150°C
-Temperature Max (T _{S max})	200°C
-Time (min to max) (t _s)	60-180 seconds
T _{S max} to T _L	
-Ramp-up Rate	3°C/second max.
Time maintained above:	
-Temperature (T _L)	217°C
-Time (t _L)	60-150 seconds
Peak Temperature (T _P)	260°C
Time within 5°C of actual Peak Temperature (t _p)	20-40 seconds
Ramp-down Rate	6°C/second max.
Time 25°C to Peak Temperature	8 minutes max.

Important Notice and Disclaimer

Leading-Tech reserves the right to make changes to this document and its products and specifications at any time without notice.

Customers should obtain and confirm the latest product information and specifications before final design, purchase or use.

Leading-Tech makes no warranty, representation or guarantee regarding the suitability of its products for any particular purpose, not does Leading-Tech assume any liability for application assistance or customer product design.

Leading-Tech does not warrant or accept any liability with products which are purchase or used for any unintended or unauthorized application.

No license is granted by implication or otherwise under any intellectual property rights of Leading-Tech.

Leading-Tech products are not authorized for use as critical components in life support devices or systems without express written approval of Leading-Tech.

Version Update information

Series NO.	Enactment/Revision Date	Effective Date	Version	Revision Content	Revision Reason	Revision Person	Note
01	2025.03.29	2025.03.29	3.0	New file	/	Ding	
02	2026.03.05	2026.03.05	3.1	Package outline E1(max)=2.6mm	/	Ding	