

P-Channel 20V(D-S) Mosfet

Features

- Low $R_{DS(on)}$ @ $V_{GS} = -4.5V$
- TrenchFET Power MOSFET
- High Current Handling Capability
- Surface Mount Package
- Lead free in comply with EU RoHS 2011/65/EU directives

Mechanical Data

- Case: SOT-23
- Approx. Weight: 8.1mg

Applications

- DC/DC Converter for Portable Devices
- High-side Load Switch
- High Speed Line Driver

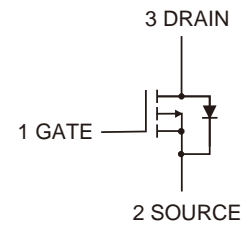
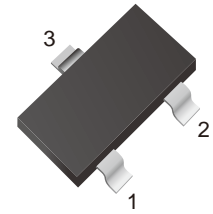

Ordering Information

Part Number	Marking	Shipping	Reel
LT2301S-TR3	A1SHB	3000PCS Tape&Reel	7 inchs
LT2301S-TR12	A1SHB	12000PCS Tape&Reel	13 inchs

Product Summary

V_{DS}	$R_{DS(on)MAX}$
-20V	140m Ω @ $V_{GS} = -4.5V$
	210m Ω @ $V_{GS} = -2.5V$

Maximum Ratings and Thermal Characteristics ($T_a = 25$ unless otherwise noted)

Parameter	Symbol	Value	Unit
Drain-Source Voltage	V_{DS}	- 20	V
Gate-Source Voltage	V_{GS}	± 10	
Continuous Drain Current	I_D	-2.3	A
Pulsed Drain Current (note1)	I_{DM}	-9	
Maximum Power Dissipation	P_D	1	W
Thermal Resistance from Junction to Ambient (note 2)	$R_{\theta JA}$	125	$^{\circ}C/W$
Operation Junction and Storage Temperature Range	T_J, T_{STG}	-50 ~+150	$^{\circ}C$

Electrical Characteristics ($T_a=25$ unless otherwise specified)

Parameter	Symbol	Test Condition	Min	Typ	Max	Unit
Static						
Drain-source breakdown voltage	$V_{(BR)DSS}$	$V_{GS} = 0V, I_D = -250\mu A$	-20			V
Gate-threshold voltage(note 3)	$V_{GS(th)}$	$V_{DS}=V_{GS}, I_D = -250\mu A$	-0.4	-0.6	-1.0	
Gate-body leakage current	I_{GSS}	$V_{DS}=0V, V_{GS}=\pm 10V$			± 100	nA
Zero gate voltage drain current	I_{DSS}	$V_{DS}=-20V, V_{GS}=0V$			-1	μA
Drain-source on-resistance(note 3)	$r_{DS(on)}$	$V_{GS}=-4.5V, I_D=-2A$		0.125	0.14	Ω
		$V_{GS}=-3.3V, I_D=-1A$		0.14	0.17	
		$V_{GS}=-2.5V, I_D=-1A$		0.17	0.21	
Diode forward voltage (note 3)	V_{SD}	$I_S=-1A, V_{GS}=0V$		-0.83	-1.2	V
Dynamic						
Input capacitance	C_{iss}	$V_{DS}=-10V, V_{GS}=0V, f=1MHz$		177		μF
Output capacitance	C_{oss}			30		
Reverse transfer capacitance	C_{rss}			25		
Switching (note 4)						
Turn-on delay time	$t_{d(on)}$	$V_{DD}=-10V, I_D=-2A, R_G=3.3\Omega, V_{GS}=-4.5V$		11		ns
Turn-on rise time	t_r			32		
Turn-off delay time	$t_{d(off)}$			25		
Turn-off fall time	t_f			38		
Total gate charge	Q_g	$V_{DS}=-10V, I_D=-2A, V_{GS}=-4.5V$		5.3		nC
Gate-source charge	Q_{gs}			0.7		
Gate-drain charge	Q_{gd}			1.4		

*Notes :

1. Repetitive rating: Pulse width limited by maximum junction temperature
2. Surface Mounted on FR4 board, $t \leq 10$ sec.
3. Pulse test : Pulse width $\leq 300\mu s$, duty cycle $\leq 2\%$.
4. Guaranteed by design, not subject to production.

Characteristic Curves

Fig1. Typical Output Characteristics

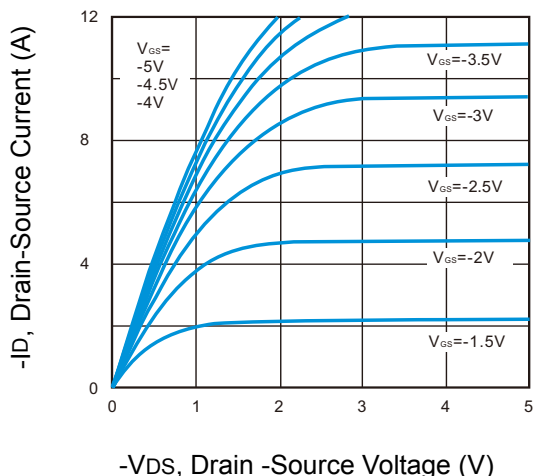

Fig2. Normalized Threshold Voltage Vs Temperature

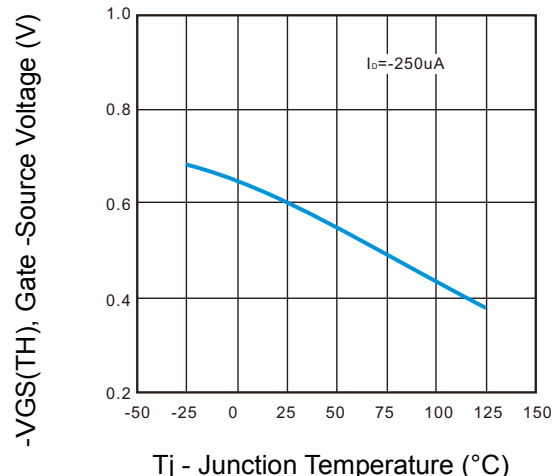



Fig3. Typical Transfer Characteristics

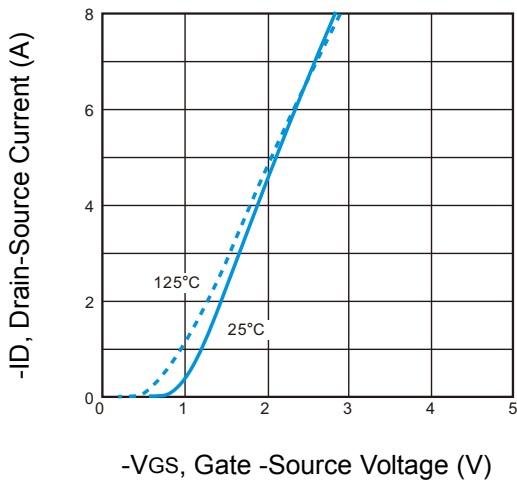

Fig4. Drain-Source Voltage vs Gate-Source Voltage

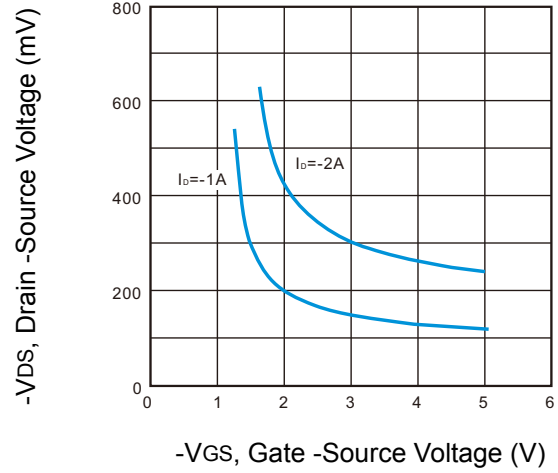

Fig5. Typical Source-Drain Diode Forward Voltage

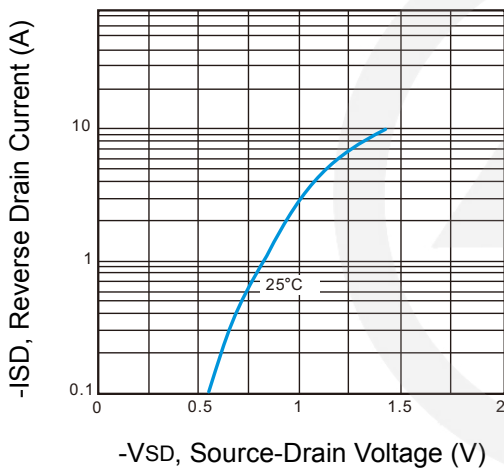

Fig6. Maximum Safe Operating Area

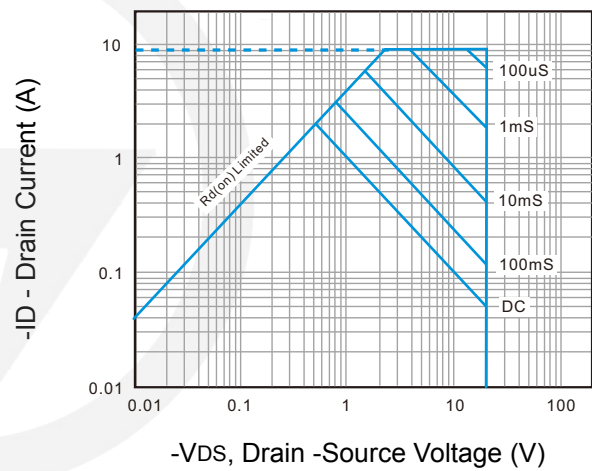

Fig7. Typical Capacitance Vs Drain-Source Voltage

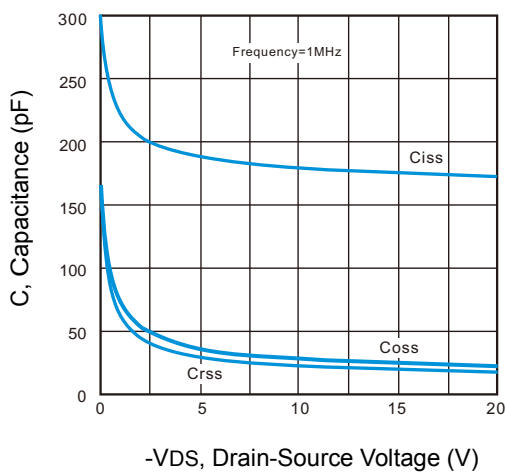
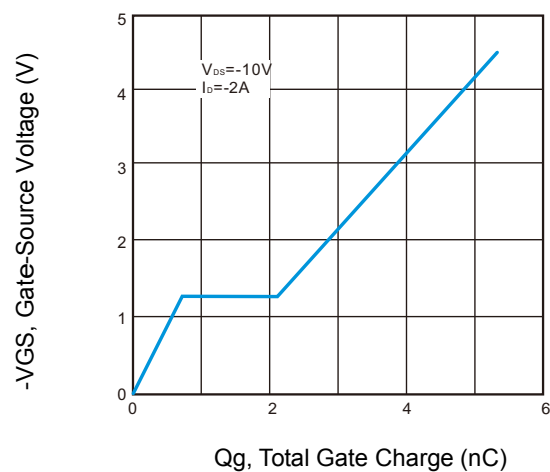
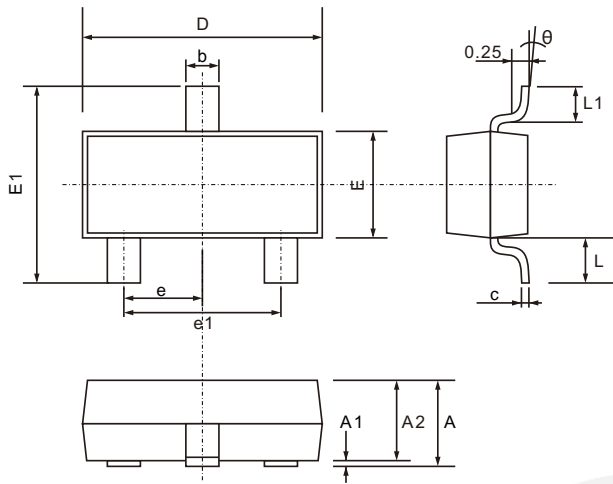

Fig8. Typical Gate Charge Vs Gate-Source Voltage



SOT-23 Package Outline

Unit: mm



SYMBOL	DIMENSIONS	
	MIN.	MAX.
A	0.900	1.200
A1	0.000	0.100
A2	0.900	1.050
b	0.300	0.500
c	0.080	0.200
D	2.700	3.100
E	1.200	1.400
E1	2.200	2.600
e	0.950 TYP.	
e1	1.750	2.050
L	0.550 TYP.	
L1	0.300	0.500
θ	0°	8°

SOT-23 Suggested Pad Layout

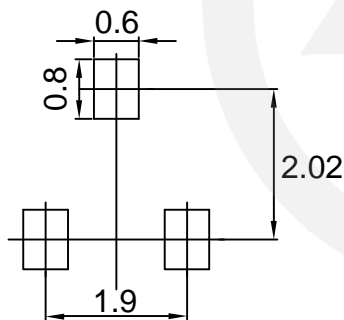

Note:
 1. Controlling dimension: in millimeters.
 2. General tolerance: $\pm 0.05\text{mm}$
 3. The pad layout is for reference purpose only.

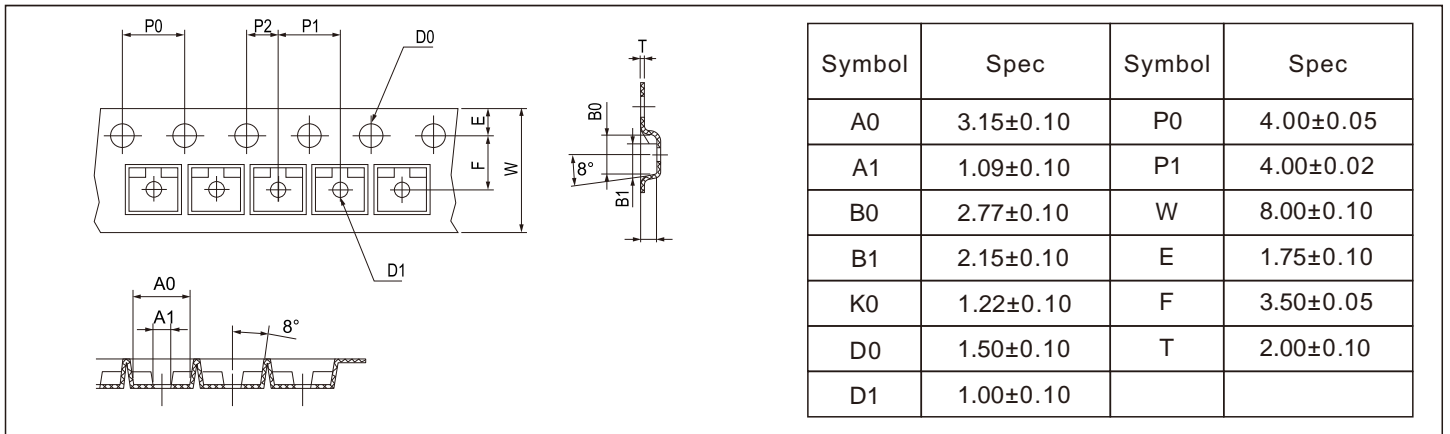
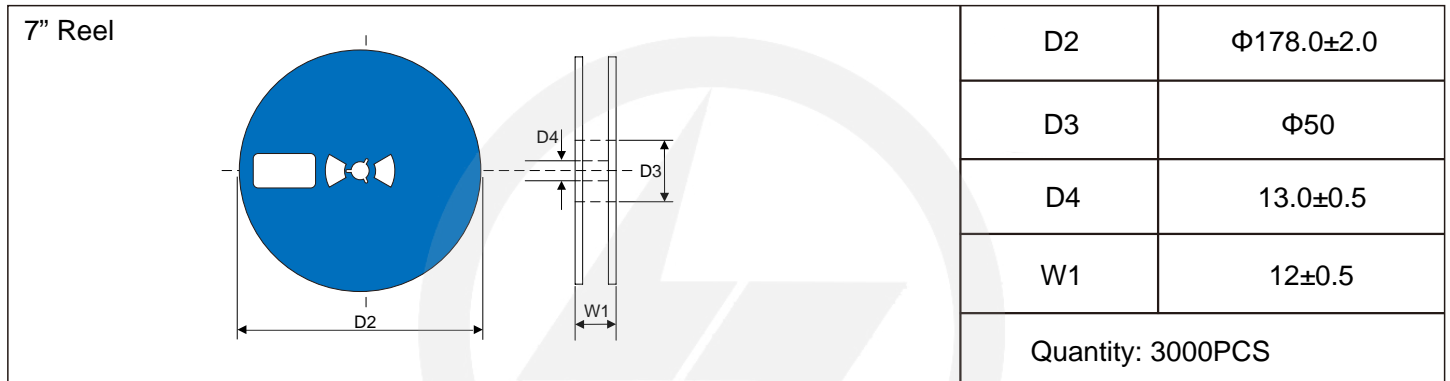
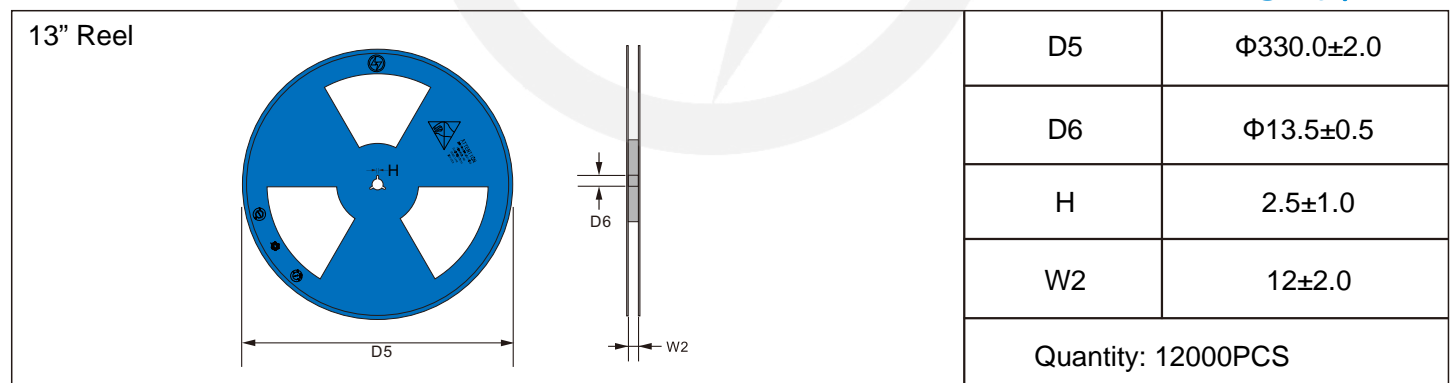
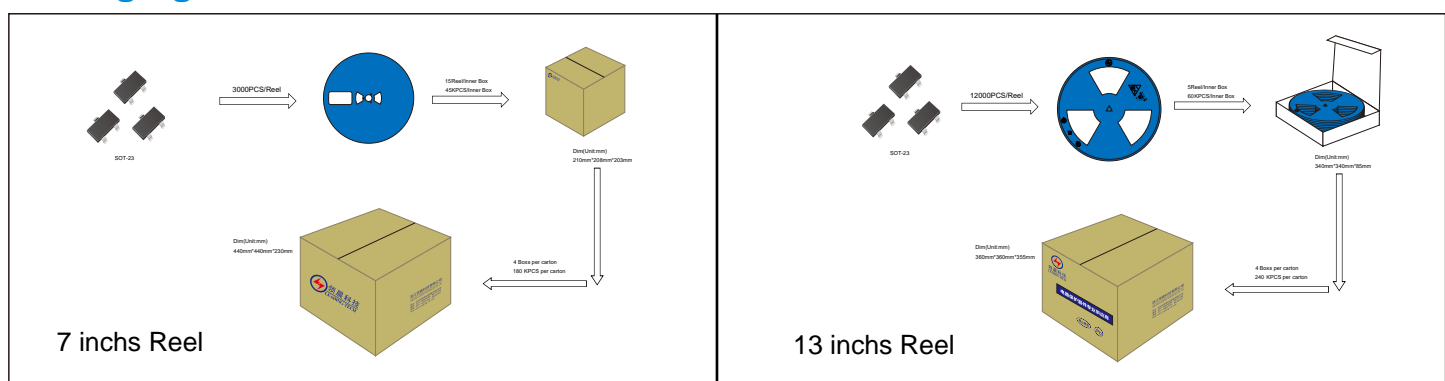
Carrier Tape Dimensions
Unit : mm

Reel Dimensions
Unit : mm

Reel Dimensions
Unit : mm

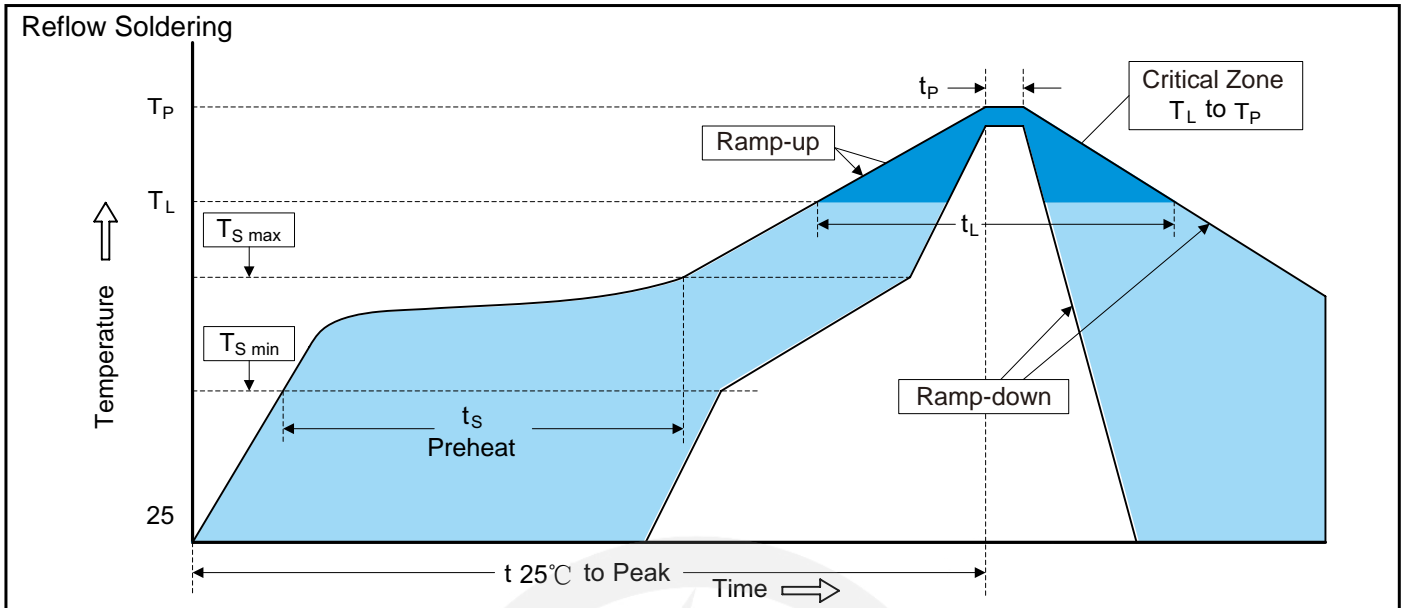
Packaging



Recommended Soldering Conditions



Recommended Conditions

Profile Feature	Pb-Free Assembly
Average ramp-up rate (T _L to T _P)	3°C/second max.
Preheat	
-Temperature Min (T _{S min})	150°C
-Temperature Max (T _{S max})	200°C
-Time (min to max) (t _s)	60-180 seconds
T _{S max} to T _L	
-Ramp-up Rate	3°C/second max.
Time maintained above:	
-Temperature (T _L)	217°C
-Time (t _L)	60-150 seconds
Peak Temperature (T _P)	260°C
Time within 5°C of actual Peak Temperature (t _p)	20-40 seconds
Ramp-down Rate	6°C/second max.
Time 25°C to Peak Temperature	8 minutes max.

Important Notice and Disclaimer

Leading-Tech reverses the right to make changes to this document and its products and specifications at any time without notice.

Customers should obtain and confirm the latest product information and specifications before final design, purchase or use.

Leading-Tech makes no warranty, representation or guarantee regarding the suitability of its products for any particular purpose, not does Leading-Tech assume any liability for application assistance or customer product design.

Leading-Tech does not warrant or accept any liability with products which are purchase or used for any unintended or unauthorized application.

No license is granted by implication or otherwise under any intellectual property rights of Leading-Tech.

Leading-Tech products are not authorized for use as critical components in life support devices or systems without express written approval of Leading-Tech.

Version Update Information

Series NO.	Enactment/Revision Date	Effective Date	Version	Revision Content	Revision Reason	Revision Person	Note
01	2024.03.20	2024.03.20	3.0	New file	/	Ding	
02	2025.06.11	2025.06.11	3.1	Update packaging information	/	Ding	
03	2026.03.05	2026.03.05	3.2	Package outline E1(max)=2.6mm	/	Ding	