

Surface Mount Schottky Barrier Rectifier

Features

- Metal silicon junction, majority carrier conduction
- For surface mounted applications
- Low power loss, high efficiency
- High forward surge current capability
- For use in low voltage, high frequency inverters, free wheeling, and polarity protection applications
- Lead free in comply with EU RoHS 2011/65/EU directives



Mechanical Data

- Case: SOD-123FL
- Terminals: Solderable per MIL-STD-750, Method 2026
- Polarity: Color band denotes cathode end

Ordering Information

Part Number	Shipping	Reel
LT22L THRU LT220L-TR3	3000PCS Tape&Reel	7 inches
LT22L THRU LT220L-TR12	12000PCS Tape&Reel	13 inches

Maximum Ratings and Electrical Characteristics

Ratings at 25 °C ambient temperature unless otherwise specified. Single phase, half wave, 60Hz resistive or inductive load, for capacitive load, derate by 20 %

Parameter	Symbol	LT22L	LT24L	LT26L	LT28L	LT210L	LT212L	LT215L	LT220L	Unit
Maximum Repetitive Peak Reverse Voltage	V_{RRM}	20	40	60	80	100	120	150	200	V
Maximum RMS voltage	V_{RMS}	14	28	42	56	70	84	105	140	V
Maximum DC Blocking Voltage	V_{DC}	20	40	60	80	100	120	150	200	V
Maximum Average Forward Rectified Current	$I_{F(AV)}$	2.0								A
Peak Forward Surge Current, 8.3ms Single Half Sine-wave Superimposed on Rated Load (JEDEC method)	I_{FSM}	50								A
Max Instantaneous Forward Voltage at 2 A	V_F	0.55	0.70	0.85	0.95					V
Maximum DC Reverse Current $T_a = 25^{\circ}C$ at Rated DC Reverse Voltage $T_a = 100^{\circ}C$	I_R	0.5 5			0.3 3				mA	
Typical Junction Capacitance (Note1)	C_j	220	80							pF
Typical Thermal Resistance (Note2)	$R_{\theta JA}$	85								$^{\circ}C/W$
Operating Junction Temperature Range	T_j	-55 ~ +125								$^{\circ}C$
Storage Temperature Range	T_{stg}	-55 ~ +150								$^{\circ}C$

Note: (1) Measured at 1 MHz and applied reverse voltage of 4V D.C.
 (2) P.C.B. mounted with 2.0" x 2.0" (5cm x 5cm) copper pad areas.



Characteristics Curve

Fig.1 Forward Current Derating Curve

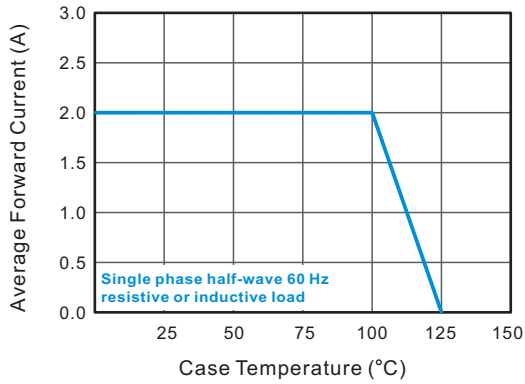

Fig.2 Typical Reverse Characteristics

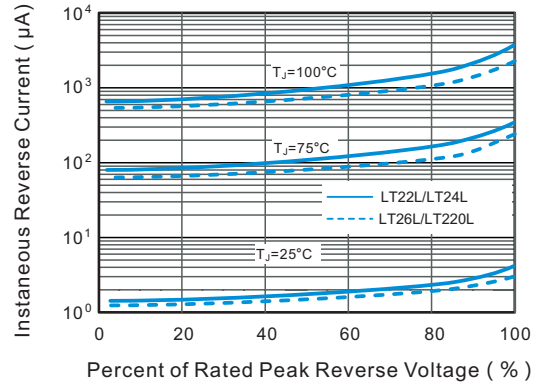

Fig.3 Typical Forward Characteristic

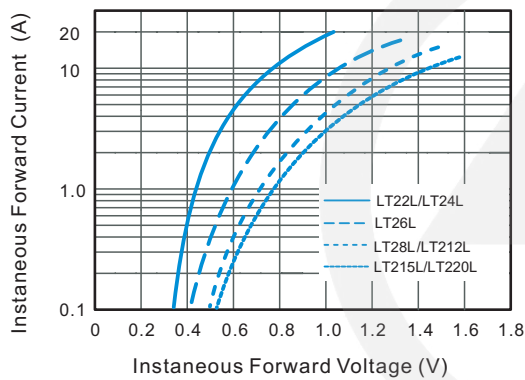

Fig.4 Typical Junction Capacitance

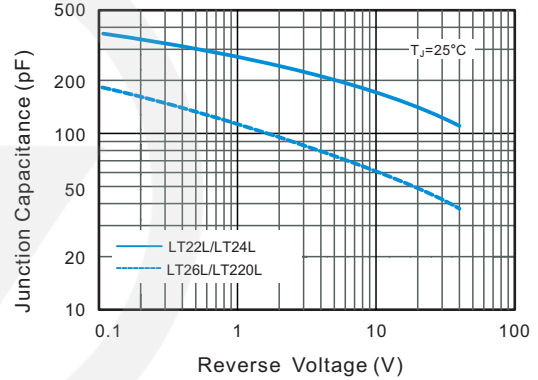

Fig.5 Maximum Non-Repetitive Peak Forward Surge Current

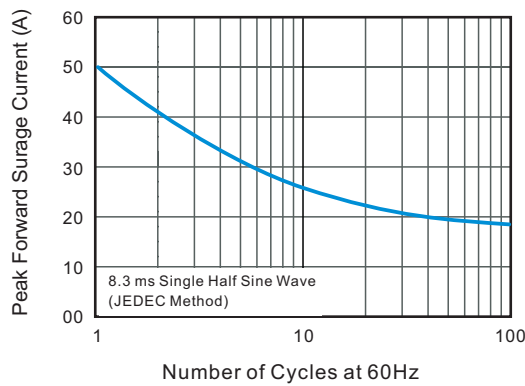
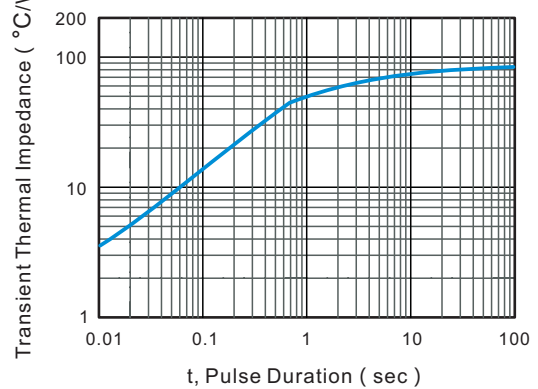
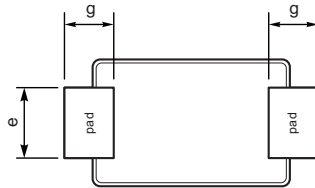
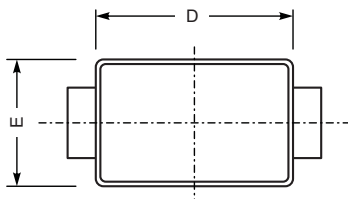
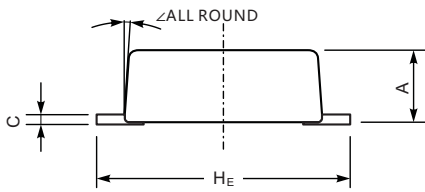

Fig.6 Typical Transient Thermal Impedance



SOD-123FL Package Outline

Unit: mm



SYMBOL	DIMENSIONS	
	MIN.	MAX.
A	0.9	1.35
C	0.12	0.20
D	2.6	2.9
E	1.75	1.95
e	0.8	1.1
g	0.7	0.9
H _E	3.5	3.8
∠	7°	

SOD-123FL Suggested Pad Layout

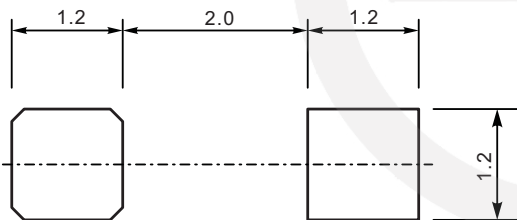

Note:

1. Controlling dimension: in millimeters.
2. General tolerance: $\pm 0.05\text{mm}$
3. The pad layout is for reference purpose only.

Marking

Type number	Marking code
LT22L	S22
LT24L	S24
LT26L	S26
LT28L	S28
LT210L	S210
LT212L	S212
LT215L	S215
LT220L	S220

Carrier Tape Dimensions

Unit : mm

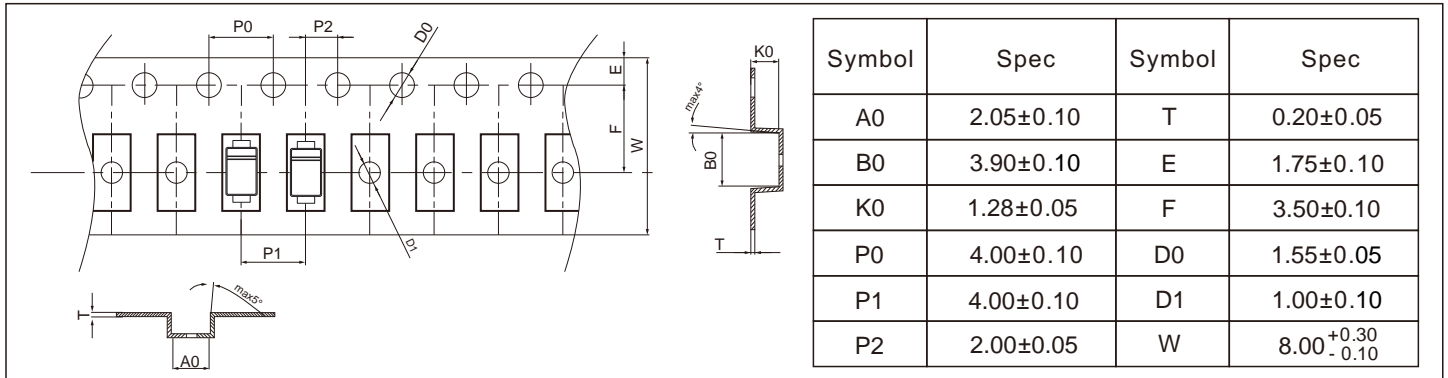

Reel Dimensions

Unit : mm

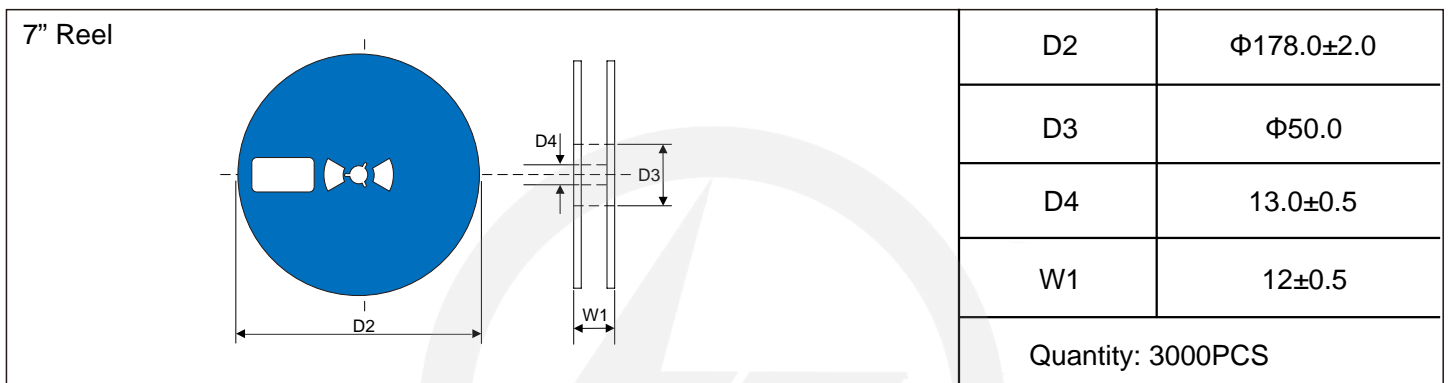

Reel Dimensions

Unit : mm

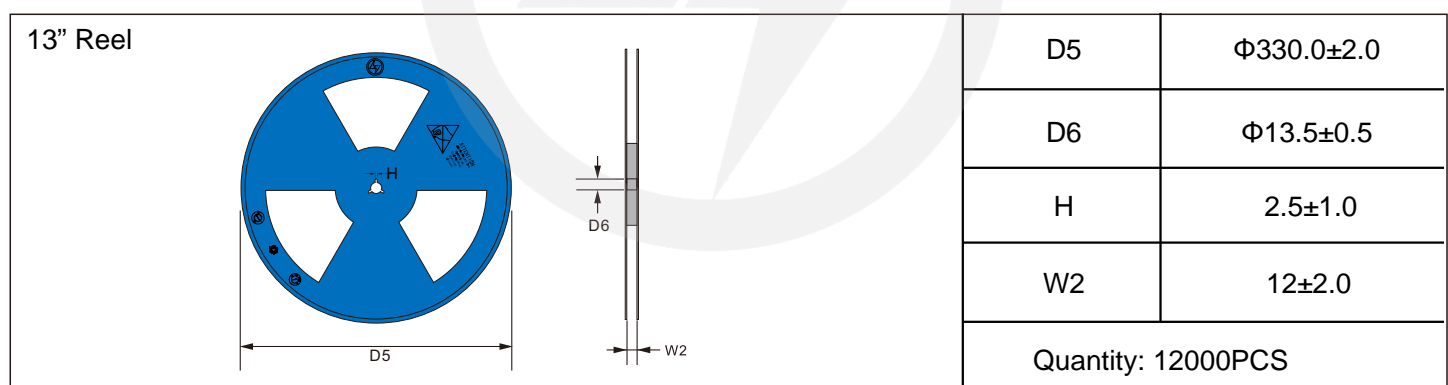

Packaging

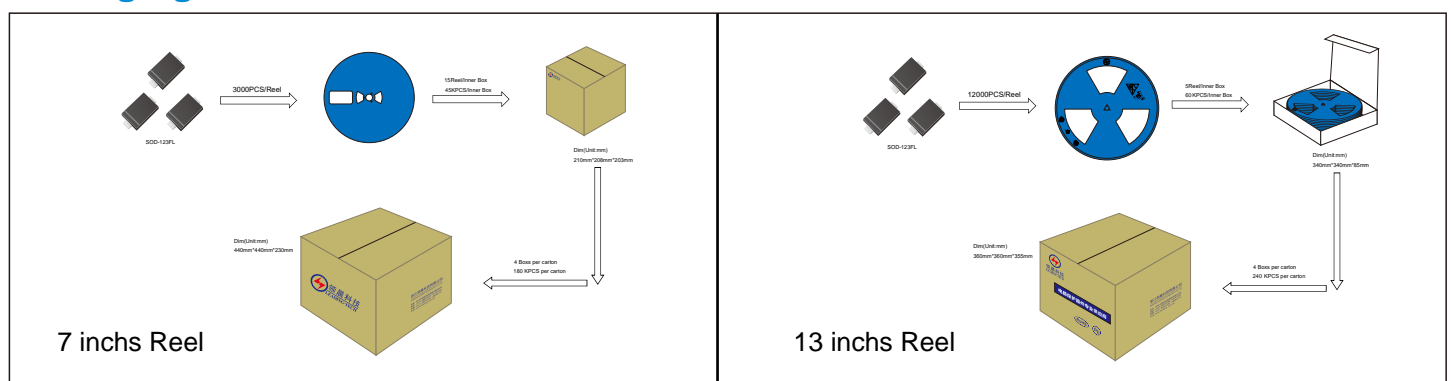



Recommended Soldering Conditions



Recommended Conditions

Profile Feature	Pb-Free Assembly
Average ramp-up rate (T _L to T _P)	3°C/second max.
Preheat	
-Temperature Min (T _{S min})	150°C
-Temperature Max (T _{S max})	200°C
-Time (min to max) (t _s)	60-180 seconds
T _{S max} to T _L	
-Ramp-up Rate	3°C/second max.
Time maintained above:	
-Temperature (T _L)	217°C
-Time (t _L)	60-150 seconds
Peak Temperature (T _P)	260°C
Time within 5°C of actual Peak Temperature (t _p)	20-40 seconds
Ramp-down Rate	6°C/second max.
Time 25°C to Peak Temperature	8 minutes max.

Important Notice and Disclaimer

Leading-Tech reverses the right to make changes to this document and its products and specifications at any time without notice.

Customers should obtain and confirm the latest product information and specifications before final design, purchase or use.

Leading-Tech makes no warranty, representation or guarantee regarding the suitability of its products for any particular purpose, not does Leading-Tech assume any liability for application assistance or customer product design.

Leading-tech does not warrant or accept any liability with products which are purchase or used for any unintended or unauthorized application.

No license is granted by implication or otherwise under any intellectual property rights of Leading-Tech.

Leading-Tech products are not authorized for use as critical components in life support devices or systems without express written approval of Leading-tech.

Version Update Information

Series NO.	Enactment/Revision Date	Effective Date	Version	Revision content	Revision Reason	Revision Person	Note
01	2024.3.17	2024.3.17	3.0	New File	/	Ding	
02	2025.06.12	2025.06.12	3.1	Update packaging information	/	Ding	