

Surface Mount Schottky Barrier Rectifier

Features

- Metal silicon junction, majority carrier conduction
- For surface mounted applications
- Low power loss, high efficiency
- High forward surge current capability
- For use in low voltage, high frequency inverters, free wheeling, and polarity protection applications
- Lead free in comply with EU RoHS 2011/65/EU directives

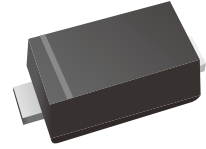

Mechanical Data

- Case: SMAF
- Terminals: Solderable per MIL-STD-750, Method 2026
- Approx. Weight: 27mg / 0.00095oz
- Polarity: Color band denotes cathode end

Ordering Information

Part Number	Shipping	Reel
LT22AF THRU LT220AF-TR3	3000PCS Tape&Reel	7 inchs
LT22AF THRU LT220AF-TR10	10000PCS Tape&Reel	13 inchs

Absolute Maximum Ratings and Electiral characteristics

Ratings at 25 °C ambient temperature unless otherwise specified.

Single phase, half wave, 60Hz resistive or inductive load, for capacitive load, derate by 20 %

Parameter	Symbol	LT22AF	LT24AF	LT26AF	LT28AF	LT210AF	LT212AF	LT215AF	LT220AF	Unit
Maximum Repetitive Peak Reverse Voltage	V_{RRM}	20	40	60	80	100	120	150	200	V
Maximum RMS voltage	V_{RMS}	14	28	42	56	70	84	105	140	V
Maximum DC Blocking Voltage	V_{DC}	20	40	60	80	100	120	150	200	V
Maximum Average Forward Rectified Current	$I_{F(AV)}$	2.0								A
Peak Forward Surge Current, 8.3ms Single Half Sine-wave Superimposed on Rated Load (JEDEC method)	I_{FSM}	50								A
Max Instantaneous Forward Voltage at 2 A	V_F	0.55		0.7	0.85		0.95			V
Maximum DC Reverse Current $T_a = 25^{\circ}C$ at Rated DC Reverse Voltage $T_a = 100^{\circ}C$	I_R	0.5 5			0.3 3					mA
Typical Junction Capacitance (Note1)	C_J	160			80					pF
Typical Thermal Resistance (Note2)	$R_{\theta JA}$	80								$^{\circ}C/W$
Operating Junction Temperature Range	T_J	-55 ~ +150								$^{\circ}C$
Storage Temperature Range	T_{stg}	-55 ~ +150								$^{\circ}C$

Note: (1) Measured at 1 MHz and applied reverse voltage of 4 V D.C.

(2) P.C.B. mounted with 2.0" x 2.0" (5cm x 5cm) copper pad areas.



Characteristics Curves

Fig.1 Forward Current Derating Curve

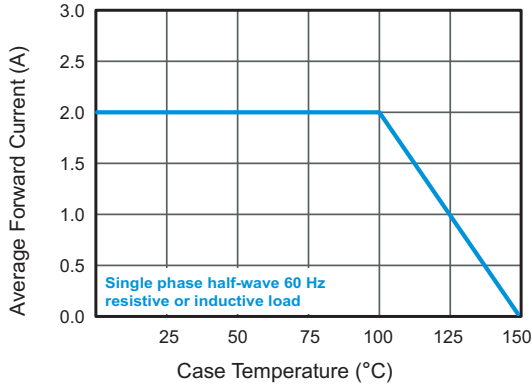

Fig.2 Typical Reverse Characteristics

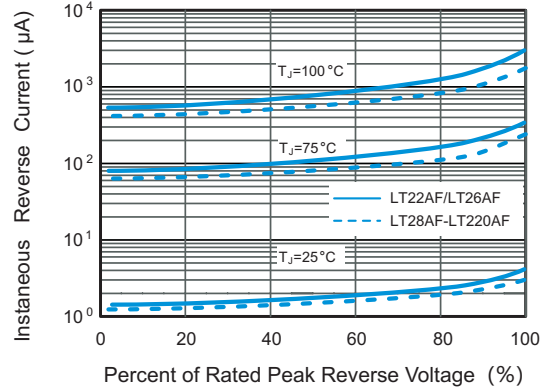

Fig.3 Typical Forward Characteristic

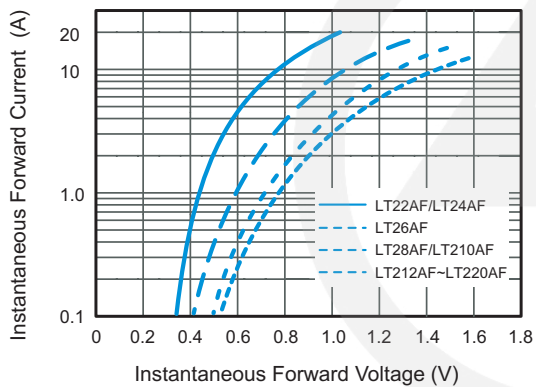

Fig.4 Typical Junction Capacitance

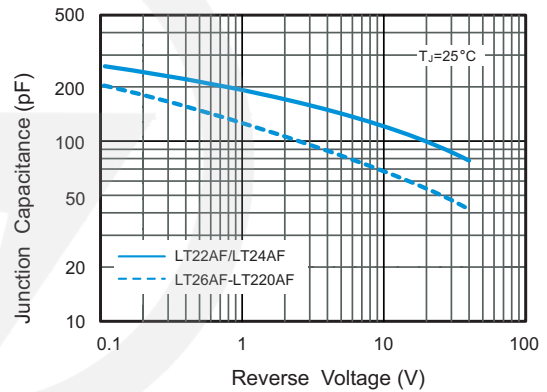
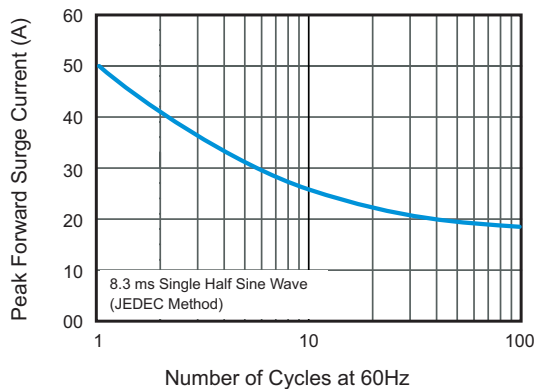
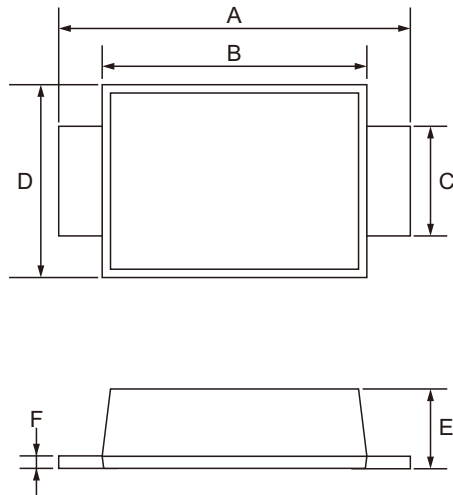

Fig.5 Maximum Non-Repetitive Peak Forward Surge Current



SMAF Package Outline



SYMBOL	DIMENSIONS	
	MIN.	MAX.
A	4.40	4.90
B	3.30	3.70
C	1.30	1.60
D	2.40	2.70
E	0.90	1.20
F	0.12	0.20

SMAF Suggested Pad Layout

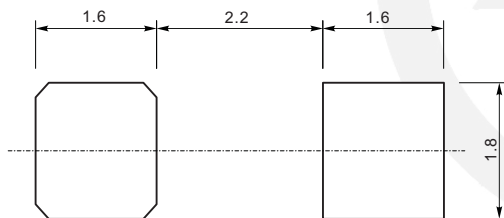

Note:
 1. Controlling dimension: in millimeters.
 2. General tolerance: $\pm 0.05\text{mm}$
 3. The pad layout is for reference purpose only.

Marking

Type number	Marking code
LT22AF	SS22
LT24AF	SS24 or RG1
LT26AF	SS26
LT28AF	SS28
LT210AF	SS210
LT212AF	SS212
LT215AF	SS215
LT220AF	SS220

Carrier Tape Dimensions

Unit : mm

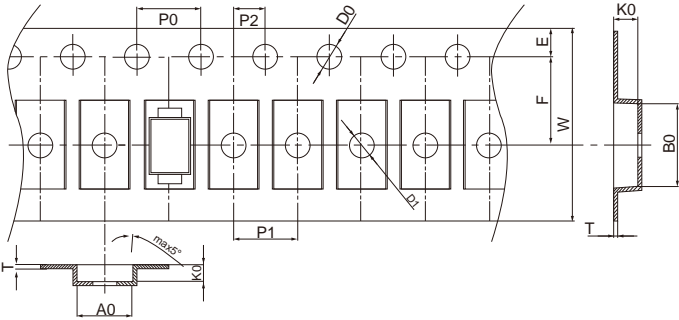
			
Symbol	Spec	Symbol	Spec
A0	2.93±0.10	T	0.20±0.03
B0	5.33±0.10	E	1.73±0.10
K0	1.33±0.10	F	5.50±0.10
P0	4.00±0.10	D0	1.55±0.05
P1	4.00±0.10	D1	1.50±0.05
P2	2.00±0.10	W	12.0±0.30

Reel Dimensions

Unit : mm

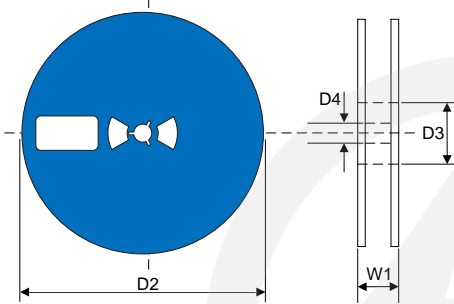
<p>7" Reel</p> 		D2	Φ178.0±2.0
		D3	Φ50.0
		D4	13.0±0.5
		W1	12±0.5
		Quantity: 3000PCS	

Reel Dimensions

Unit : mm

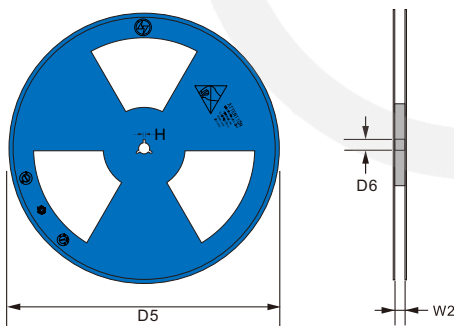
<p>13" Reel</p> 		D5	Φ330.0±2.0
		D6	Φ13.5±0.5
		H	2.5±1.0
		W2	12±2.0
		Quantity: 10000PCS	

Packaging

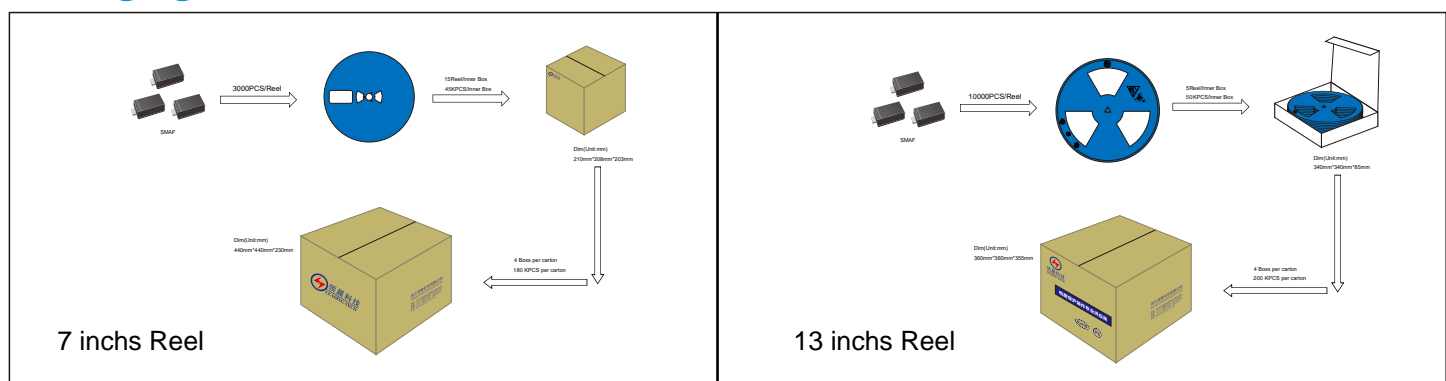



Recommended Soldering Conditions



Recommended Conditions

Profile Feature	Pb-Free Assembly
Average ramp-up rate (T _L to T _P)	3°C/second max.
Preheat	
-Temperature Min (T _{S min})	150°C
-Temperature Max (T _{S max})	200°C
-Time (min to max) (t _s)	60-180 seconds
T _{S max} to T _L	
-Ramp-up Rate	3°C/second max.
Time maintained above:	
-Temperature (T _L)	217°C
-Time (t _L)	60-150 seconds
Peak Temperature (T _P)	260°C
Time within 5°C of actual Peak Temperature (t _p)	20-40 seconds
Ramp-down Rate	6°C/second max.
Time 25°C to Peak Temperature	8 minutes max.

Important Notice and Disclaimer

Leading-Tech reserves the right to make changes to this document and its products and specifications at any time without notice.

Customers should obtain and confirm the latest product information and specifications before final design, purchase or use.

Leading-Tech makes no warranty, representation or guarantee regarding the suitability of its products for any particular purpose, not does Leading-Tech assume any liability for application assistance or customer product design.

Leading-tech does not warrant or accept any liability with products which are purchase or used for any unintended or unauthorized application.

No license is granted by implication or otherwise under any intellectual property rights of Leading-Tech.

Leading-Tech products are not authorized for use as critical components in life support devices or systems without express written approval of Leading-tech.

Version Update Information

Series NO.	Enactment/Revision Date	Effective Date	Version	Revision content	Revision Reason	Revision Person	Note
01	2024.3.18	2024.3.18	3.0	New File	/	Ding	
02	2025.06.18	2025.06.18	3.1	Update packaging information	/	Ding	