

## Zener Diodes

### Features

- Low Zener Impedance
- Power Dissipation of 500mW
- High Stability and High Reliability
- Lead free in comply with EU RoHS 2011/65/EU directives

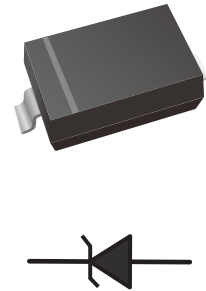

### Mechanical Data

- Case: SOD-123
- Package Polarity: Color band denotes cathode end
- Epoxy UL: 94V-0
- Mounting Position: Any

### Ordering Information

Part Number	Shipping	Reel
LT1ZxxWT-TR3	3000PCS Tape&Reel	7 inchs
LT1ZxxWT-TR12	12000PCS Tape&Reel	13 inchs

### Maximum Ratings and Electrical Characteristics

Ratings at 25 °C ambient temperature unless otherwise specified.

Parameters	Symbol	Value	Unit
Power Dissipation	Pd	500 <sup>1)</sup>	mW
Forward Voltage @IF=10mA	Vf	0.9 <sup>2)</sup>	V
Storage and junction temperature range	Ts ,Tj	-55-+150	°C
Thermal Resistance Junction to Ambient air	RθJA	250	°C/W

Note : (1) Device mounted on ceramic PCB: 7.6mm x 9.4mm x 0.87mm with pad areas 25mm<sup>2</sup>

(2) Short duration test pulse used to minimize self-heating effect

(3) f=1KHz



## Electrical Characteristics

(Ratings at 25°C ambient temperature unless otherwise specified)

Device	Marking	Zener Voltage Range				Maximum Zener Impedance			Maximum Reverse Current		Typical Temperature coefficient @ IZTC=mV/°C		Test Current IZTC
		Vz@Izt			Izt	Zzt @Izt	Zzk @Izk	Izk	IR	VR	Min	Max	
		Nom(V)	Min(V)	Max(V)	mA	Ω	mA	uA	V				
LT1Z3V0WT	W2	3.0	2.8	3.2	5	95	600	1.0	10	1.0	-3.5	0	5
LT1Z3V3WT	W3	3.3	3.1	3.5	5	95	600	1.0	5	1.0	-3.5	0	5
LT1Z3V6WT	W4	3.6	3.4	3.8	5	90	600	1.0	5	1.0	-3.5	0	5
LT1Z3V9WT	W5	3.9	3.7	4.1	5	90	600	1.0	3	1.0	-3.5	0	5
LT1Z4V3WT	W6	4.3	4.0	4.6	5	90	600	1.0	3	1.0	-3.5	0	5
LT1Z4V7WT	W7	4.7	4.4	5.0	5	80	500	1.0	3	2.0	-3.5	0.2	5
LT1Z5V1WT	W8	5.1	4.8	5.4	5	60	480	1.0	2	2.0	-2.7	1.2	5
LT1Z5V6WT	W9	5.6	5.2	6.0	5	40	400	1.0	1	2.0	-2.0	2.5	5
LT1Z6V2WT	WA	6.2	5.8	6.6	5	10	150	1.0	3	4.0	0.4	3.7	5
LT1Z6V8WT	WB	6.8	6.4	7.2	5	15	80	1.0	2	4.0	1.2	4.5	5
LT1Z7V5WT	4Y	7.5	7.0	7.9	5	15	80	1.0	1	5.0	2.5	5.3	5
LT1Z8V2WT	WD	8.2	7.7	8.7	5	15	80	1.0	0.7	5.0	3.2	6.2	5
LT1Z9V1WT	WE	9.1	8.5	9.6	5	15	100	1.0	0.5	6.0	3.8	7.0	5
LT1Z10WT	WF	10	9.4	10.6	5	20	150	1.0	0.2	7.0	4.5	8.0	5
LT1Z11WT	WG	11	10.4	11.6	5	20	150	1.0	0.1	8.0	5.4	9.0	5
LT1Z12WT	WH	12	11.4	12.7	5	25	150	1.0	0.1	8.0	6.0	10.0	5
LT1Z13WT	WI	13	12.4	14.1	5	30	170	1.0	0.1	8.0	7.0	11.0	5
LT1Z15WT	WJ	15	13.8	15.6	5	30	200	1.0	0.1	10.5	9.2	13.0	5
LT1Z16WT	5H	16	15.3	17.1	5	40	200	1.0	0.1	11.2	10.4	14.0	5
LT1Z18WT	WL	18	16.8	19.1	5	45	225	1.0	0.1	12.6	12.4	16.0	5
LT1Z20WT	WM	20	18.8	21.2	5	55	225	1.0	0.1	14.0	14.4	18.0	5
LT1Z22WT	WN	22	20.8	23.3	5	55	250	1.0	0.1	15.4	16.4	20.0	5
LT1Z24WT	WO	24	22.8	25.6	5	70	250	1.0	0.1	16.8	18.4	22.0	5
LT1Z27WT	WP	27	25.1	28.9	2	80	300	0.5	0.1	18.9	21.4	25.3	2
LT1Z30WT	WQ	30	28.0	32.0	2	80	300	0.5	0.1	21.0	24.4	29.4	2
LT1Z33WT	WR	33	31.0	35.0	2	80	325	0.5	0.1	23.1	27.4	33.4	2
LT1Z36WT	WS	36	34.0	38.0	2	90	350	0.5	0.1	25.2	30.4	37.4	2
LT1Z39WT	WT	39	37.0	41.0	2	130	350	0.5	0.1	27.3	33.4	41.2	2
LT1Z43WT	WU	43	40.0	46.0	2	100	700	1.0	0.1	32.0	10.0	12.0	5



Characteristics Curve

Fig.1 Zener Characteristics ( $V_z$  Up to 10 V)

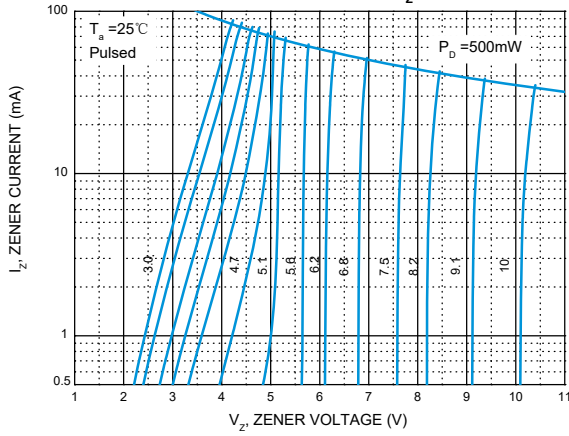

Fig.2 Zener Characteristics (11 V to 43 V)

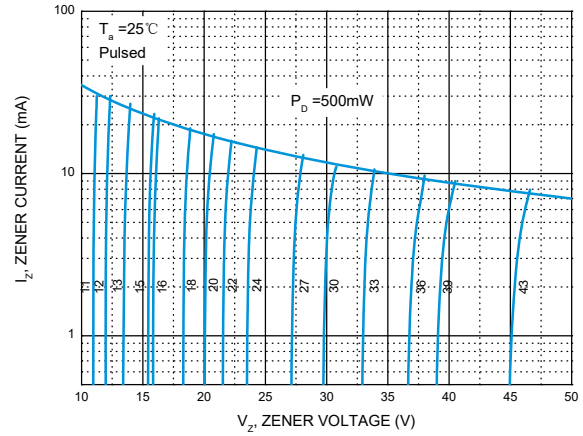

Fig.3 Temperature Coefficients

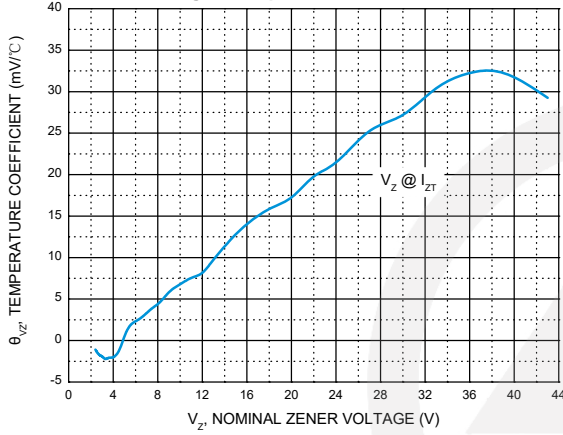

Fig.4 Typical Leakage Current

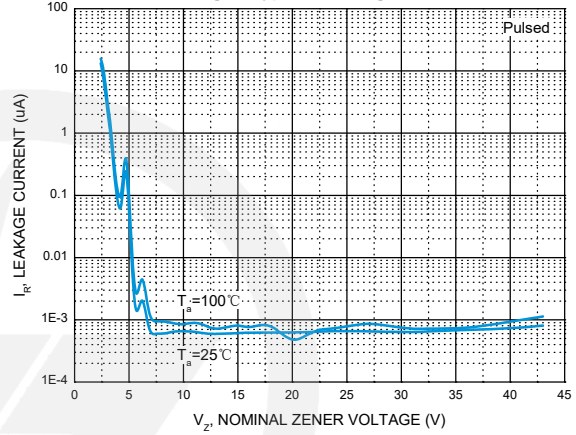

Fig.5 Typical Capacitance

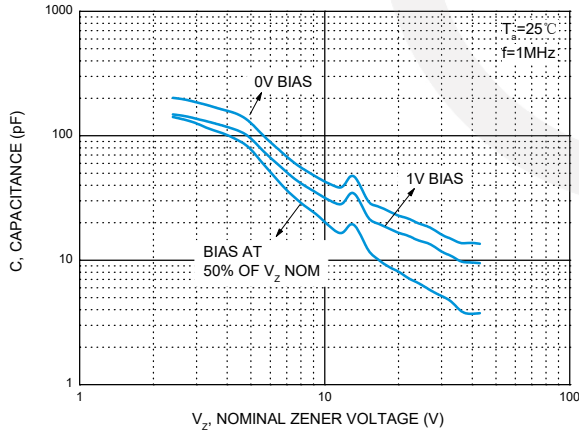

Fig.6 Effect of Zener Voltage on Zener Impedance

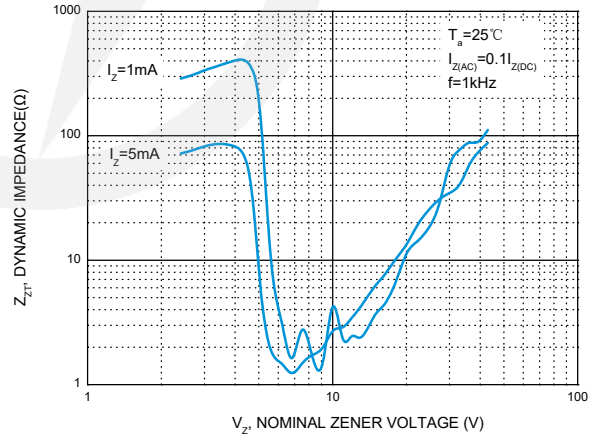
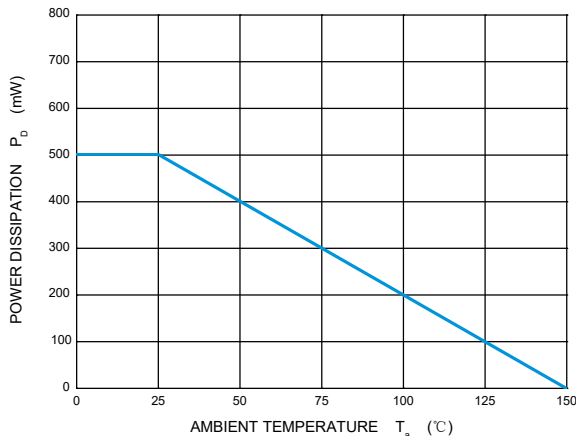
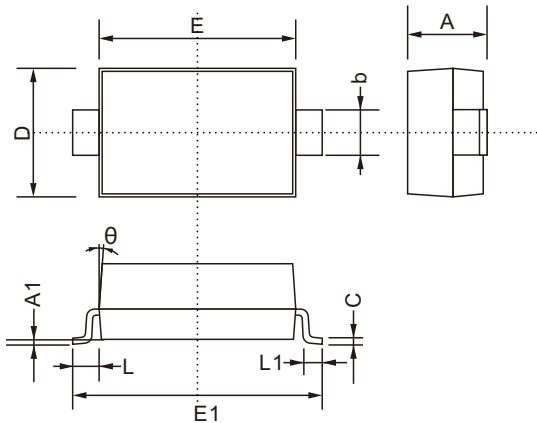

Fig.7 Power Derating Curve



## SOD-123 Package Outline

Unit: mm



SYMBOL	DIMENSIONS	
	MIN.	MAX.
A	0.900	1.300
A1	0.000	0.200
b	0.450	0.750
C	0.080	0.230
D	1.500	1.800
E	2.500	2.800
E1	3.550	3.900
L1	0.250	0.450
L	0.5REF	
$\theta$	8°	

## SOD-123 Suggested Pad Layout

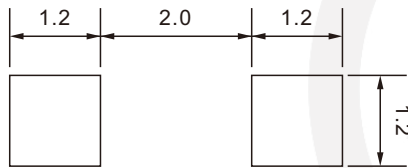

**Note:**

1. Controlling dimension: in millimeters.
2. General tolerance:  $\pm 0.05\text{mm}$
3. The pad layout is for reference purpose only.

## Carrier Tape Dimensions

Unit : mm

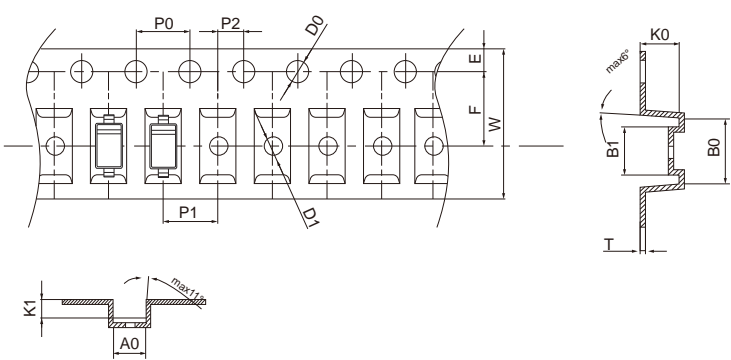

The diagram shows a top view and a cross-section of a carrier tape. The top view labels dimensions P0, P2, D0, E, F, W, P1, and D. The cross-section labels dimensions K0, B1, B0, T, and K1. A detail view shows a maximum thickness of 0.1mm.

Symbol	Spec	Symbol	Spec
A0	1.75±0.10	P2	2.00±0.05
B0	3.94±0.10	D0	1.55±0.05
B1	2.59±0.10	D1	1.00±0.10
K0	1.47±0.10	T	0.20±0.05
K1	1.30±0.05	E	1.75±0.10
P0	4.00±0.10	F	3.50±0.05
P1	4.00±0.10	W	8.00 <sup>+0.30</sup> <sub>-0.10</sub>

## Reel Dimensions

Unit : mm

7" Reel

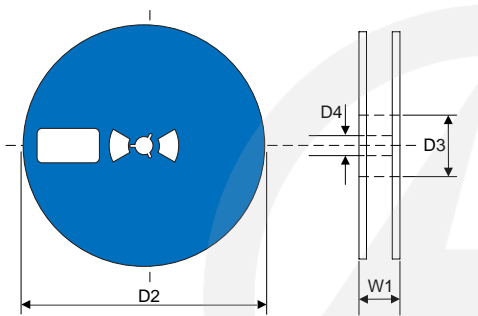

The diagram shows a top view and a side view of a 7-inch reel. The top view labels dimensions D2 and D4. The side view labels dimensions D3, D4, and W1.

D2	Φ178.0±2.0
D3	Φ50
D4	13.0±0.5
W1	12±0.5
Quantity: 3000PCS	

## Reel Dimensions

Unit : mm

13" Reel

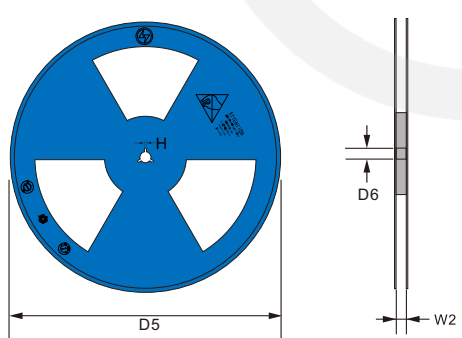

The diagram shows a top view and a side view of a 13-inch reel. The top view labels dimensions D5 and H. The side view labels dimensions D6 and W2.

D5	Φ330.0±2.0
D6	Φ13.5±0.5
H	2.5±1.0
W2	12±2.0
Quantity: 12000PCS	

## Packaging

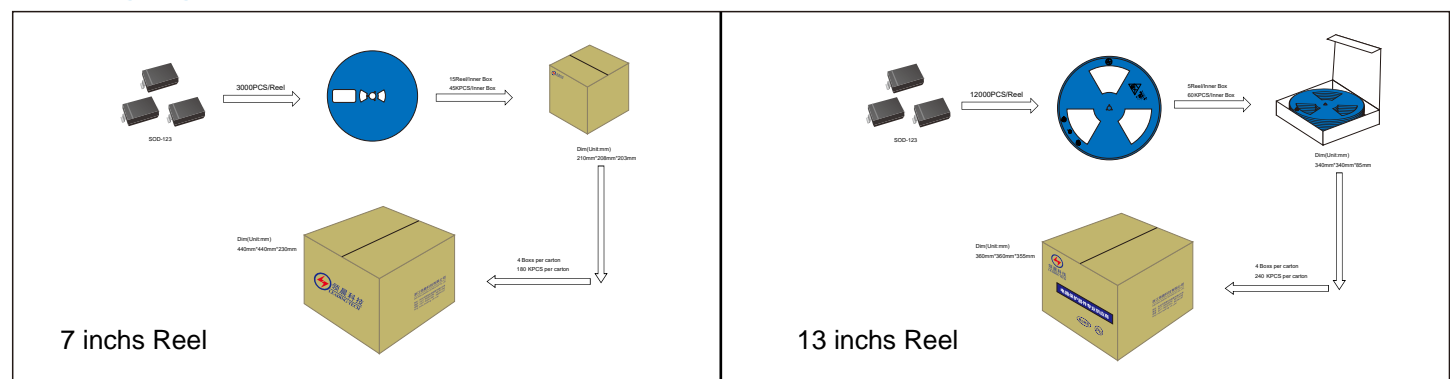



Recommended Soldering Conditions

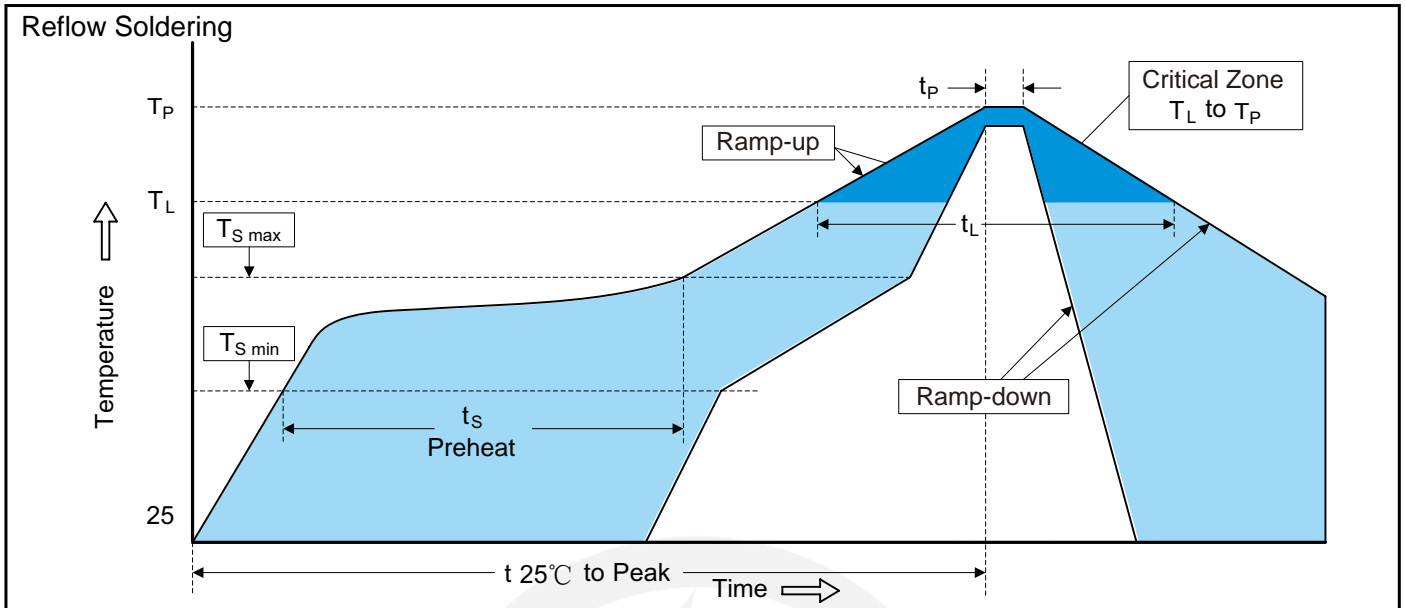

Recommended Conditions

Profile Feature	Pb-Free Assembly
Average ramp-up rate (T <sub>L</sub> to T <sub>P</sub> )	3°C/second max.
Preheat	
-Temperature Min (T <sub>S min</sub> )	150°C
-Temperature Max (T <sub>S max</sub> )	200°C
-Time (min to max) (t <sub>s</sub> )	60-180 seconds
T <sub>S max</sub> to T <sub>L</sub>	
-Ramp-up Rate	3°C/second max.
Time maintained above:	
-Temperature (T <sub>L</sub> )	217°C
-Time (t <sub>L</sub> )	60-150 seconds
Peak Temperature (T <sub>P</sub> )	260°C
Time within 5°C of actual Peak Temperature (t <sub>p</sub> )	20-40 seconds
Ramp-down Rate	6°C/second max.
Time 25°C to Peak Temperature	8 minutes max.

## Important Notice and Disclaimer

Leading-Tech reserves the right to make changes to this document and its products and specifications at any time without notice.

Customers should obtain and confirm the latest product information and specifications before final design, purchase or use.

Leading-Tech makes no warranty, representation or guarantee regarding the suitability of its products for any particular purpose, not does Leading-Tech assume any liability for application assistance or customer product design.

Leading-tech does not warrant or accept any liability with products which are purchase or used for any unintended or unauthorized application.

No license is granted by implication or otherwise under any intellectual property rights of Leading-Tech.

Leading-Tech products are not authorized for use as critical components in life support devices or systems without express written approval of Leading-tech.

## Version Update Information

Series NO.	Enactment/Revision Date	Effective Date	Version	Revision content	Revision Reason	Revision Person	Note
01	2024.3.17	2024.3.17	3.0	New File	/	Ding	
02	2025.06.12	2025.06.12	3.1	Update packaging information	/	Ding	