

Surface Mount Schottky Barrier Rectifier

Features

- The plastic package carries Underwriters Laboratory Flammability Classification 94V-0
- For surface mounted applications
- Metal silicon junction, majority carrier conduction
- Low power loss, high efficiency
- Built-in strain relief, ideal for automated placement
- High forward surge current capability
- Lead free in comply with EU RoHS 2011/65/EU directives

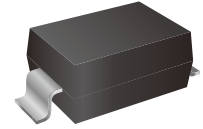

Mechanical Data

- Case: SMAW
- Terminal: Leads solderable per MIL-STD-750 Method 2026
- Polarity: Color band denotes cathode end
- Mounting Position: Any

Ordering Information

Part Number	Marking	Shipping	Reel
LT1S40W	1S40	8000PCS Tape&Reel	13 inchs

Maximum Ratings and Electrical Characteristics

Ratings at 25°C ambient temperature unless otherwise specified.
 Single phase half-wave 60Hz, resistive or inductive load, for capacitive load current derate by 20%.

Rating	Symbol	LT1S40W	Unit
Maximum repetitive peak reverse voltage	V_{RRM}	40	V
Maximum RMS voltage	V_{RMS}	28	V
Maximum DC blocking voltage	V_{DC}	40	V
Maximum average forward rectified current at T_L (see fig.1)	$I_{(AV)}$	1.0	A
Peak forward surge current 8.3ms single half sine-wave superimposed on rated load (JEDEC Method)	I_{FSM}	30	A
Maximum instantaneous forward voltage at 1A	V_F	0.45	V
Maximum DC reverse current at rated DC blocking voltage	I_R	0.2 10	mA
Maximum Thermal Resistance (Note1)	$R_{\theta JL}$	28	°C/W
Typical thermal resistance (Note2)	$R_{\theta JA}$	88	°C/W
Maximum Operating junction temperature range	T_J	-55 to +125	°C
Storage temperature range	T_{STG}	-55 to +125	°C

Note: (1) Pulse Test with $PW=300\mu\text{sec}$, 2% Duty Cycle.

(2) Mounted on P.C.Board with 5.0mm^2 (.013mm thick) copper pad areas.



Characteristics Curves

FIG.1 FORWARD CURRENT DERATING CURVE

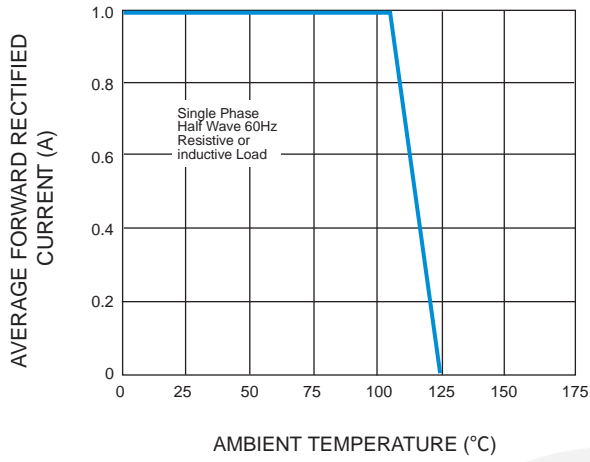

FIG.2 MAXIMUM NON-REPETITIVE PEAK FORWARD SURGE CURRENT

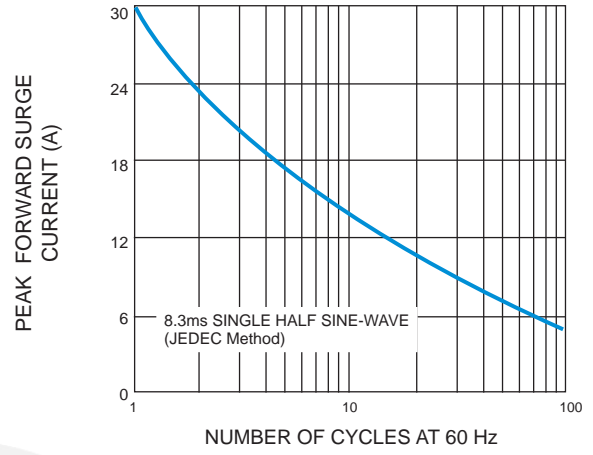

FIG.3 TYPICAL INSTANTANEOUS FORWARD CHARACTERISTICS

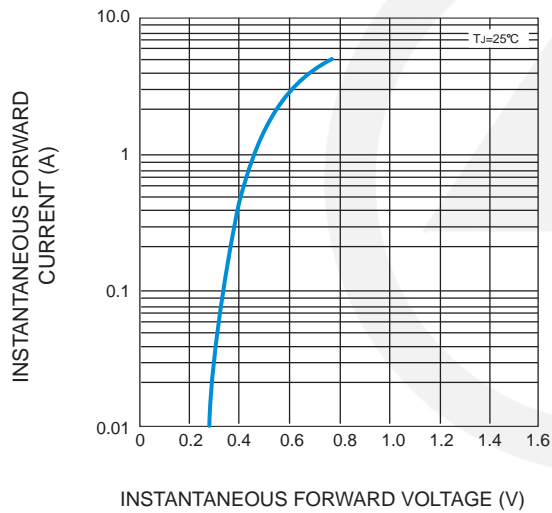

FIG.4 TYPICAL REVERSE CHARACTERISTICS

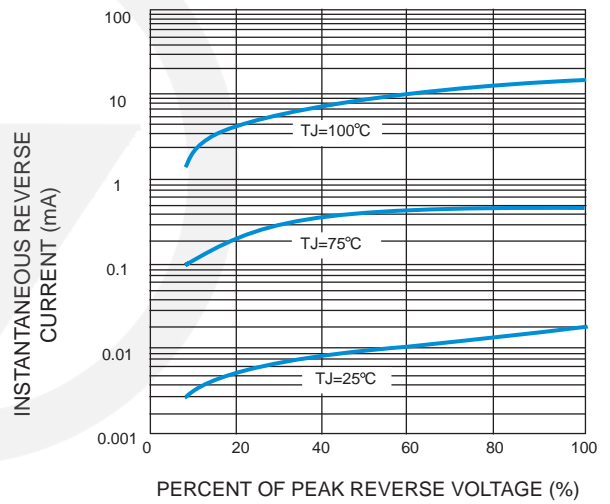

FIG.5 TYPICAL JUNCTION CAPACITANCE

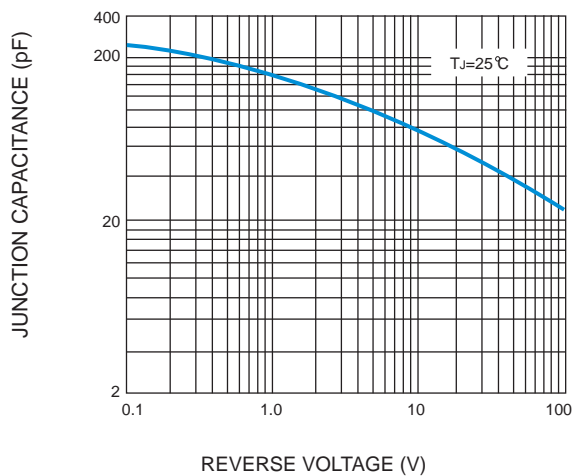
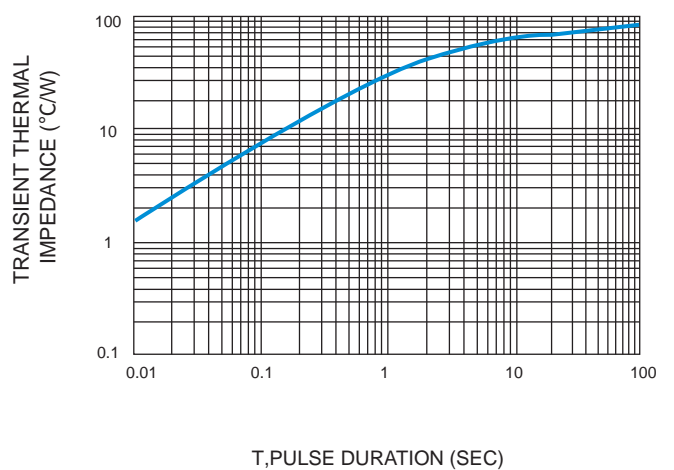
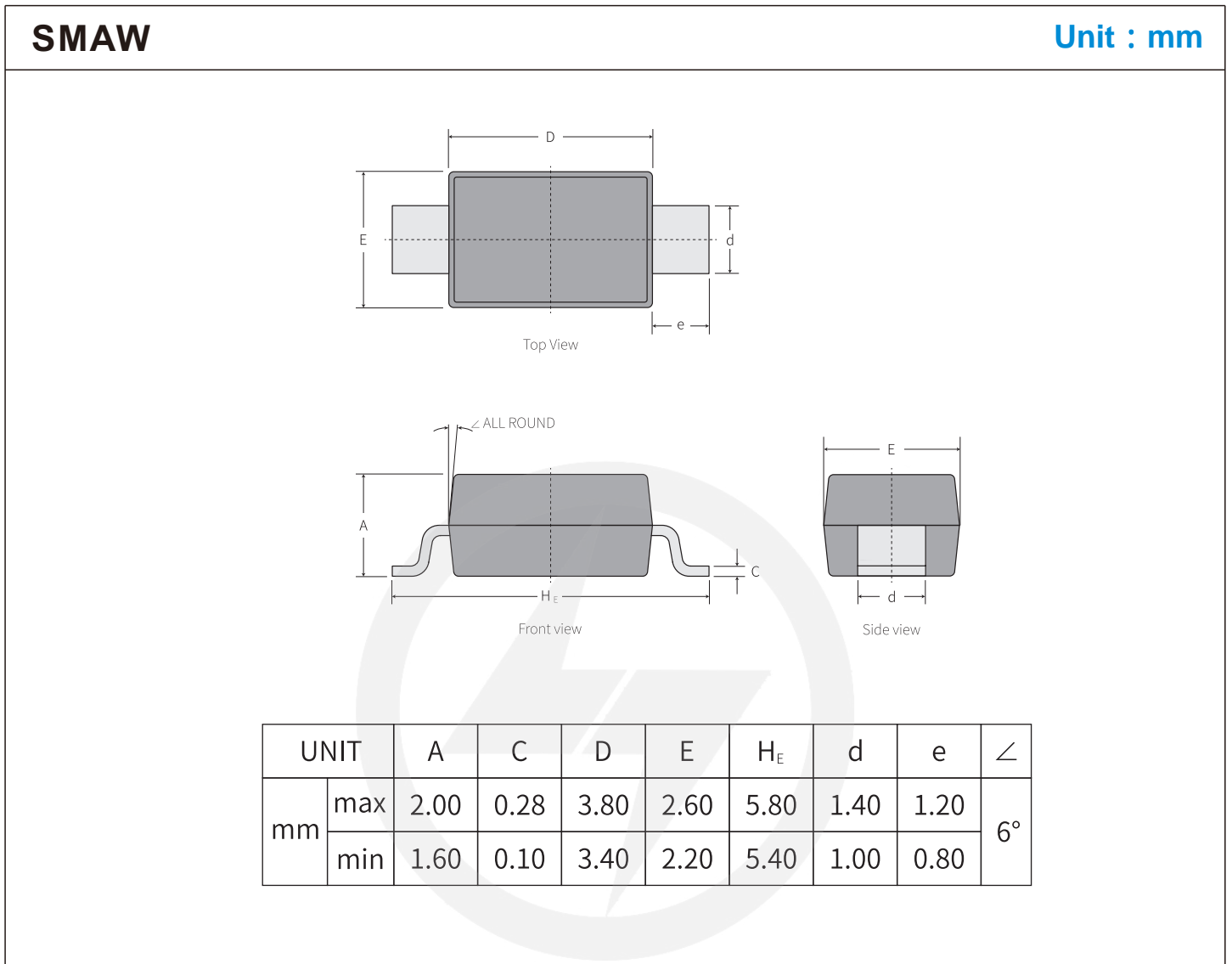
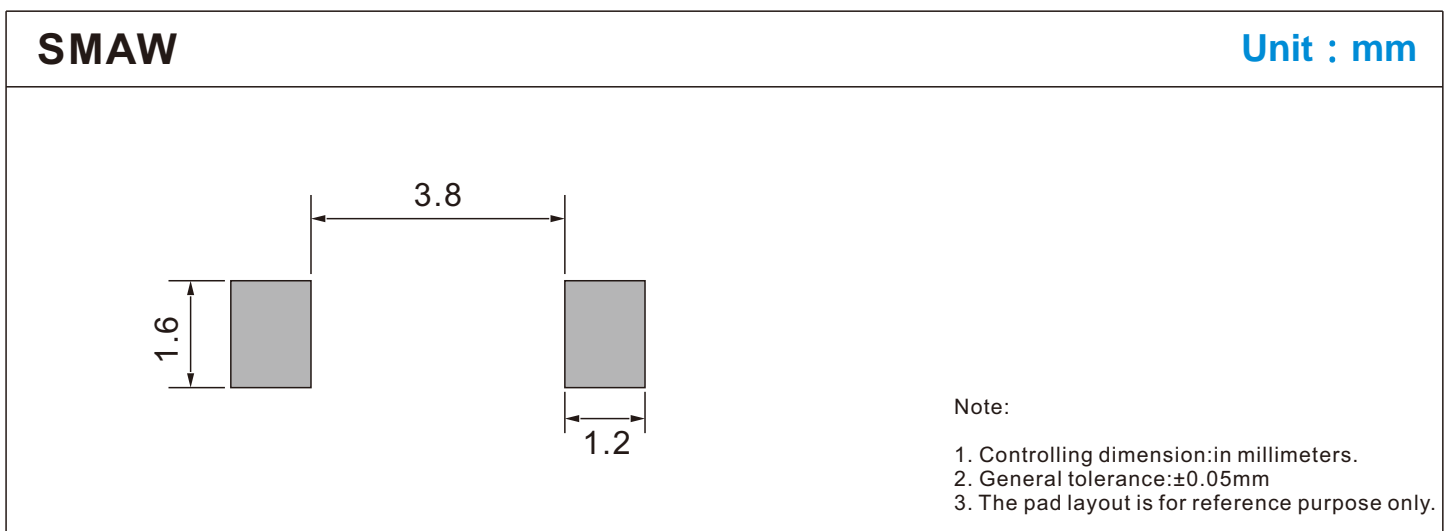

FIG.6 TYPICAL TRANSIENT THERMAL IMPEDANCE



Package Outline

Suggested Pad Layout

Carrier Tape Dimensions

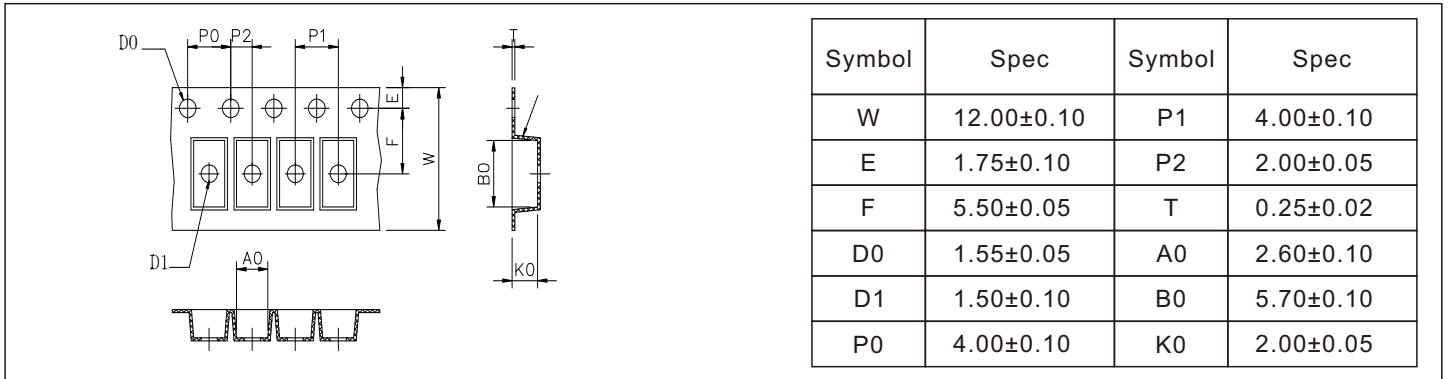
Unit : mm



Reel Dimensions

Unit : mm

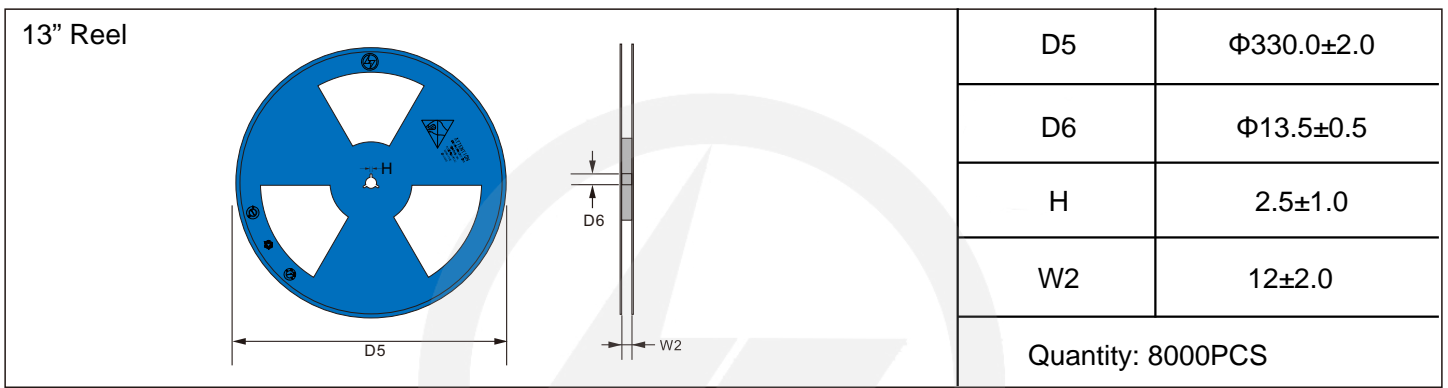

Packaging

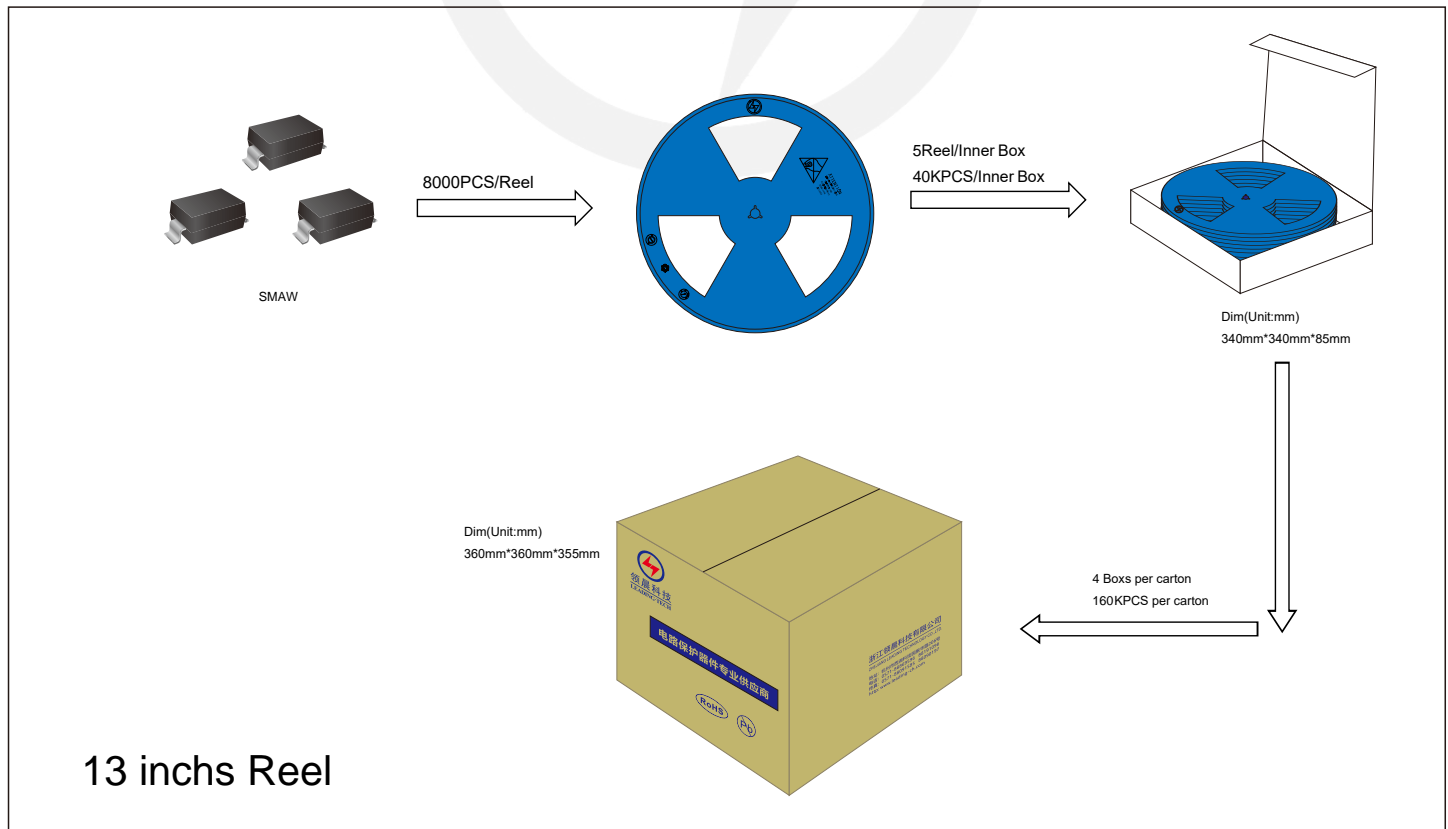



Recommended Soldering Conditions



Recommended Conditions

Profile Feature	Pb-Free Assembly
Average ramp-up rate (T _L to T _P)	3°C/second max.
Preheat	
-Temperature Min (T _{S min})	150°C
-Temperature Max (T _{S max})	200°C
-Time (min to max) (t _s)	60-180 seconds
T _{S max} to T _L	
-Ramp-up Rate	3°C/second max.
Time maintained above:	
-Temperature (T _L)	217°C
-Time (t _L)	60-150 seconds
Peak Temperature (T _P)	260°C
Time within 5°C of actual Peak Temperature (t _p)	20-40 seconds
Ramp-down Rate	6°C/second max.
Time 25°C to Peak Temperature	8 minutes max.

Important Notice and Disclaimer

Leading-Tech reserves the right to make changes to this document and its products and specifications at any time without notice.

Customers should obtain and confirm the latest product information and specifications before final design, purchase or use.

Leading-Tech makes no warranty, representation or guarantee regarding the suitability of its products for any particular purpose, not does Leading-Tech assume any liability for application assistance or customer product design.

Leading-tech does not warrant or accept any liability with products which are purchase or used for any unintended or unauthorized application.

No license is granted by implication or otherwise under any intellectual property rights of Leading-Tech.

Leading-Tech products are not authorized for use as critical components in life support devices or systems without express written approval of Leading-tech.

Version Update Information

Series NO.	Enactment/Revision Date	Effective Date	Version	Revision content	Revision Reason	Revision Person	Note
01	2024.1.23	2024.1.23	1.0	New File	/	Ding	
02	2025.6.10	2025.6.10	1.1	Modify junction temperature parameters	/	Ding	