

## Schottky Barrier Diode

### Features

- Low Forward Voltage Drop
- Guard Ring Construction for Transient Protection
- Negligible Reverse Recovery Time
- Low Capacitance
- Lead free in comply with EU RoHS 2011/65/EU directives

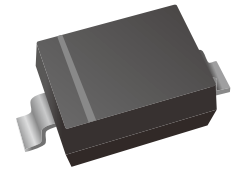

### Mechanical Date

- Case:SOD-323
- Terminals: Solderable per MIL-STD-750, Method 2026
- Polarity:Color band denotes cathode end

### Ordering Information

Part Number	Marking	Shipping	Reel
LT103AST-TR3	S4	3000PCS Tape&Reel	7 inches
LT103AST-TR12	S4	12000PCS Tape&Reel	13 inches

### Maximum Ratings and Electrical characteristics

Ratings at 25 °C ambient temperature unless otherwise specified.

Parameter	Symbol	LT103AST	Unit
Peak Repetitive Reverse Voltage	$V_{RRM}$	40	V
RMS reverse voltage	$V_{RMS}$	28	V
Working Peak Reverse Voltage	$V_{DC}$	40	V
Peak Forward Surge Current, 1.0s single half sine-wave superimposed on rated load (JEDEC method)	$I_{FSM}$	1.5	A
Maximum Instantaneous Forward Voltage	$V_F$	0.37 0.60	V
Power Dissipation	$P_D$	200	mW
Reverse current	$I_R$	5	$\mu A$
Thermal Resistance, Junction to Ambient Air	$R_{\theta JA}$	500	$^{\circ}C/W$
Reverse voltage	$V_{(BR)}$	40	V
Reverse recovery time	$t_{rr}$	10	ns
Forward Continuons Current	$I_{FM}$	350	mA
Total capacitance	$C_{tot}$	50	pF
Junction temperature	$T_j$	-55 ~ +150	$^{\circ}C$
Storage temperature	$T_{stg}$	-55 ~ +150	$^{\circ}C$

**Characteristics Curves**

**Fig.1 Forward Characteristics**

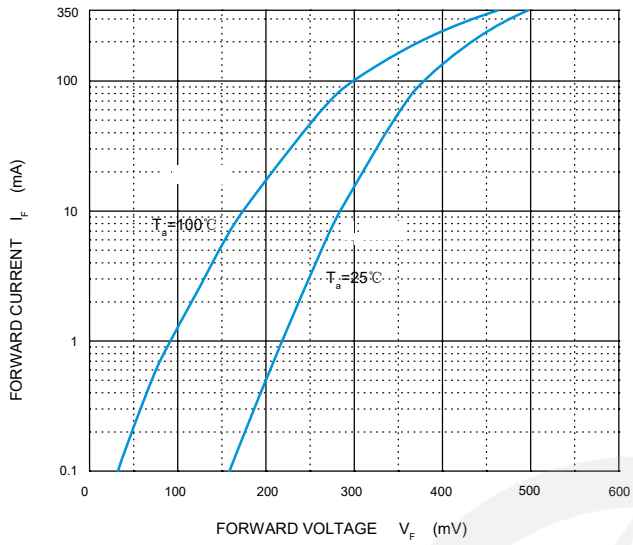

**Fig.2 Reverse Characteristics**

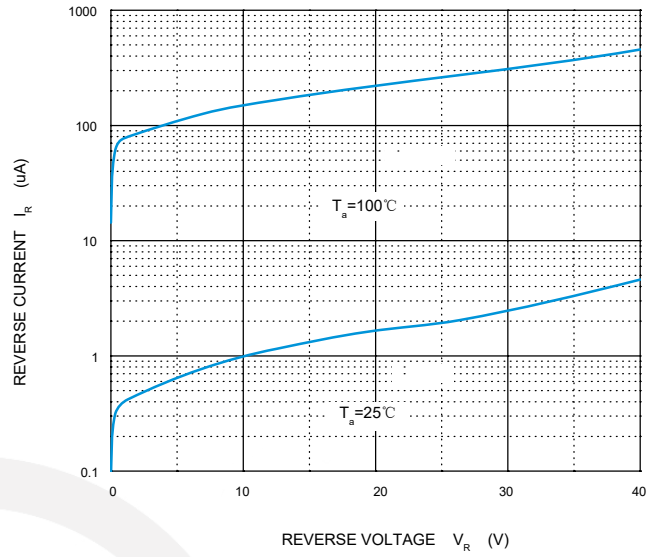

**Fig.3 Capacitance Characteristics**

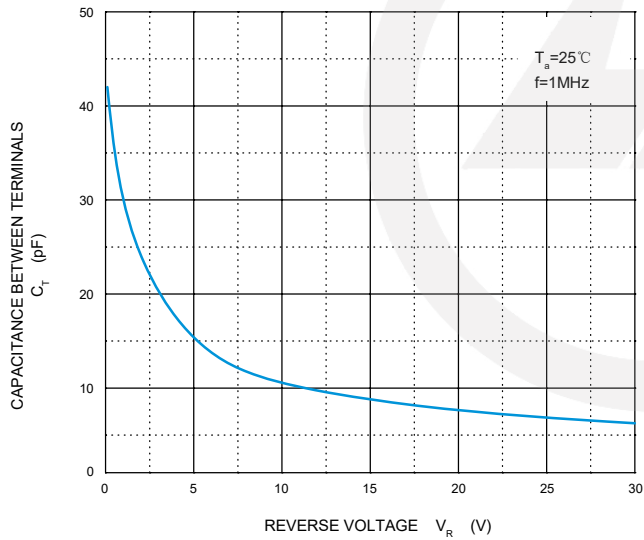

**Fig.4 Power Derating Curve**

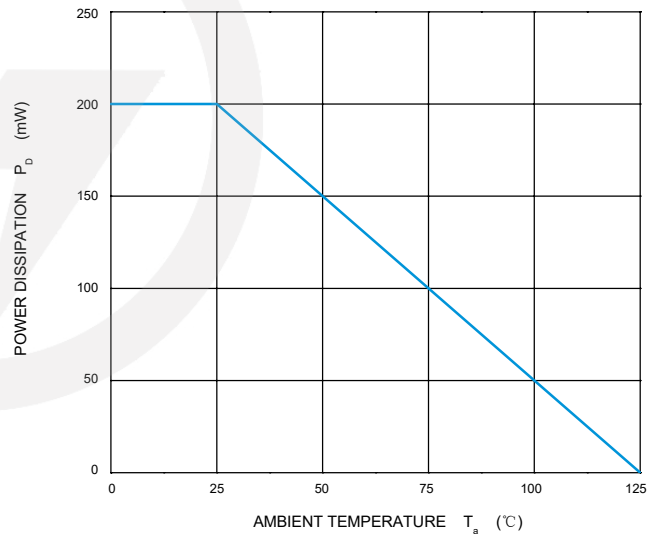



### SOD-323 Package Outline

Unit: mm

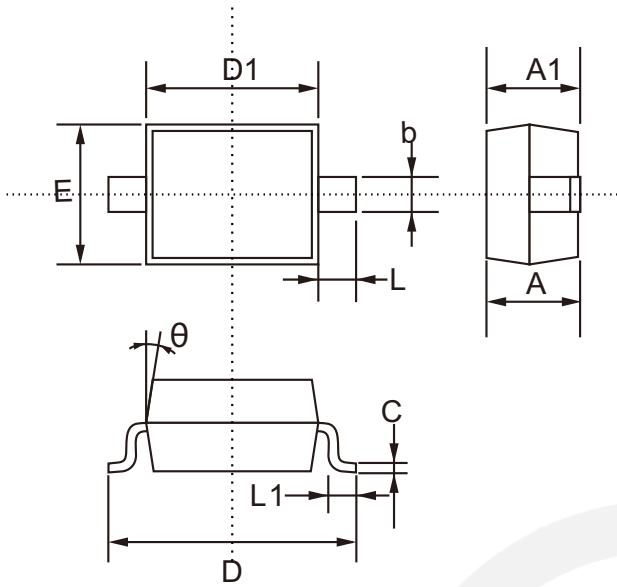

SYMBOL	DIMENSIONS	
	MIN.	MAX.
A	0.800	1.100
A1	0.800	0.900
b	0.250	0.400
C	0.080	0.177
D	2.300	2.800
D1	1.400	1.800
E	1.150	1.400
L1	0.100	0.400
L	0.475 TYP.	
$\theta$	8°	

### SOD-323 Suggested Pad Layout

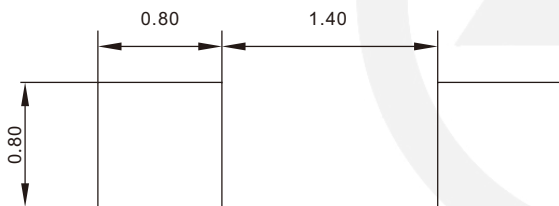

**Note:**

1. Controlling dimension: in millimeters.
2. General tolerance:  $\pm 0.05\text{mm}$
3. The pad layout is for reference purpose only.

## Carrier Tape Dimensions

Unit : mm

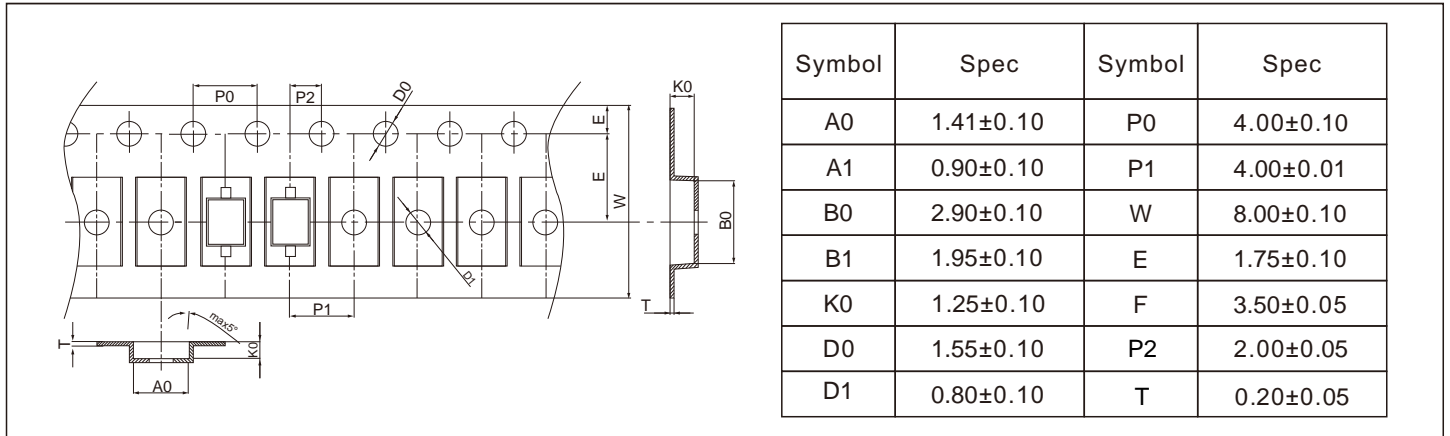

## Reel Dimensions

Unit : mm

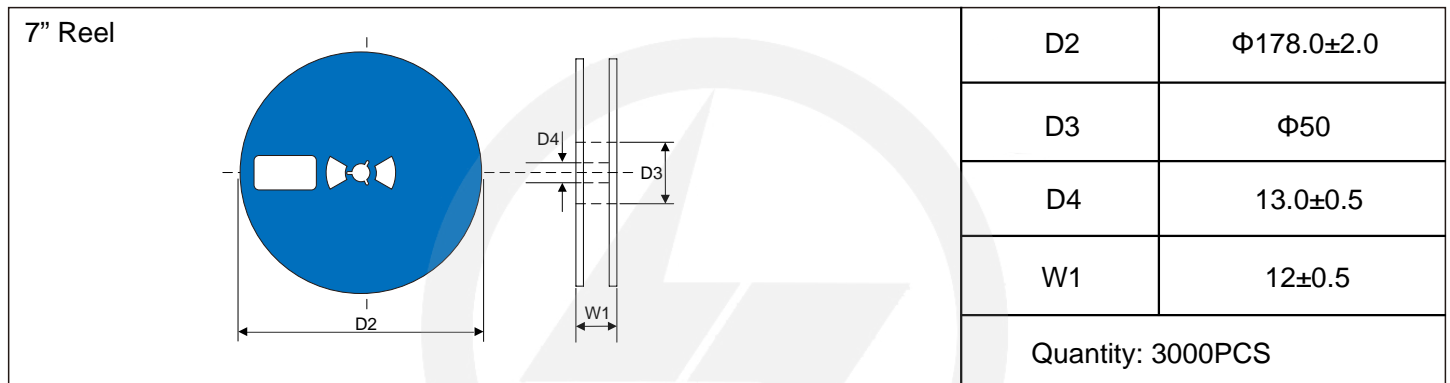

## Reel Dimensions

Unit : mm

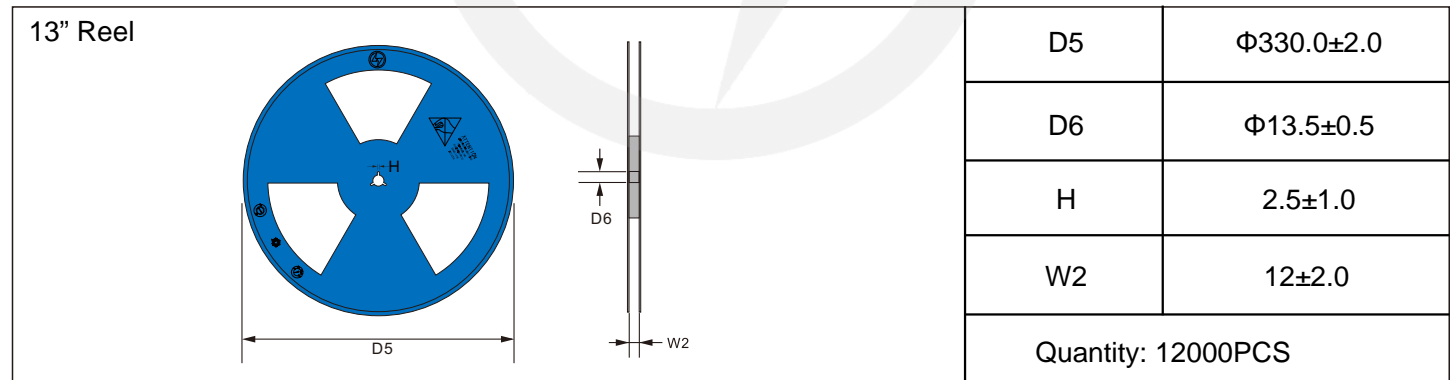

## Packaging

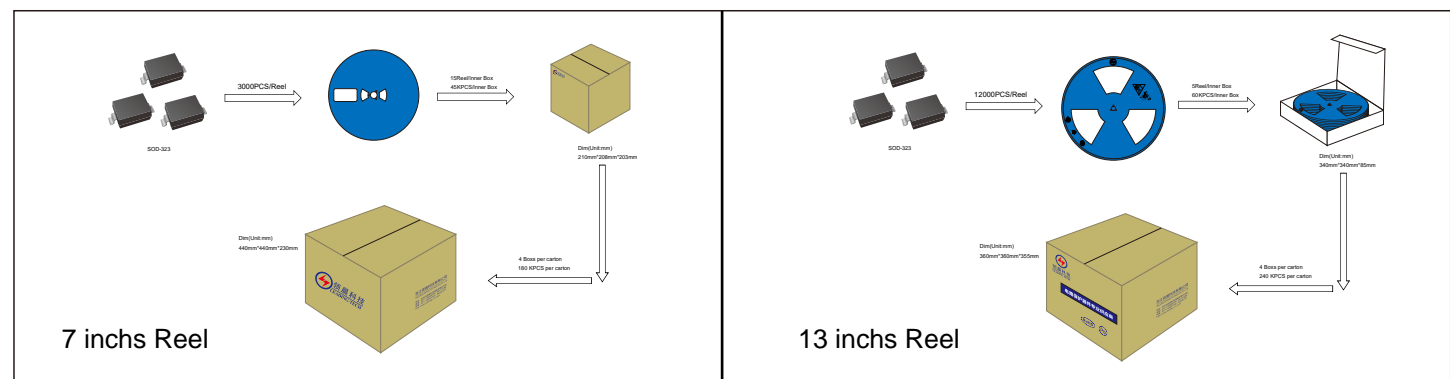



Recommended Soldering Conditions



Recommended Conditions

Profile Feature	Pb-Free Assembly
Average ramp-up rate (T <sub>L</sub> to T <sub>P</sub> )	3°C/second max.
Preheat	
-Temperature Min (T <sub>S min</sub> )	150°C
-Temperature Max (T <sub>S max</sub> )	200°C
-Time (min to max) (t <sub>s</sub> )	60-180 seconds
T <sub>S max</sub> to T <sub>L</sub>	
-Ramp-up Rate	3°C/second max.
Time maintained above:	
-Temperature (T <sub>L</sub> )	217°C
-Time (t <sub>L</sub> )	60-150 seconds
Peak Temperature (T <sub>P</sub> )	260°C
Time within 5°C of actual Peak Temperature (t <sub>p</sub> )	20-40 seconds
Ramp-down Rate	6°C/second max.
Time 25°C to Peak Temperature	8 minutes max.

## Important Notice and Disclaimer

Leading-Tech reserves the right to make changes to this document and its products and specifications at any time without notice.

Customers should obtain and confirm the latest product information and specifications before final design, purchase or use.

Leading-Tech makes no warranty, representation or guarantee regarding the suitability of its products for any particular purpose, not does Leading-Tech assume any liability for application assistance or customer product design.

Leading-Tech does not warrant or accept any liability with products which are purchase or used for any unintended or unauthorized application.

No license is granted by implication or otherwise under any intellectual property rights of Leading-Tech.

Leading-Tech products are not authorized for use as critical components in life support devices or systems without express written approval of Leading-tech.

## Version Update Information

Series NO.	Enactment/Revision Date	Effective Date	Version	Revision content	Revision Reason	Revision Person	Note
01	2024.5.12	2024.5.12	3.0	New File	/	Ding	